

Seminar Outline

- **Communications for the new Economy**
- **Wireless Technology Evolution**
- **Broadband Wireless Tutorial**
- **BLAST Tutorial: The next dimension**

BLAST Overview

- **Motivation: Overcome conventional limits**
- **The BLAST Concept: Assumptions, gains and asymptotes**
- **Experimental Evidence: Real time test bed and propagation measurements**
- **Practical Implementations: V-Blast, T-BLAST, Coding**
- **Near Term Impact: CDMA2000 and UMTS**

Space: The Last Frontier

- Convergence of **ubiquitous wireless access** and **broadband internet surfing** creates insatiable demand for **high bit rate wireless access**
- System capacity is **interference** limited - cannot be increased by increasing transmitted **power**
- The electromagnetic **spectrum** has become a scarce and very expensive resource
- Reducing cell size below 1000 ft is not viable
- Increasing **spectral efficiency** with **multiple transmit** and **multiple receive antennas** opens a new dimension, **space**, offering *exceedingly high bit rates without increasing transmitted power bandwidth allocation.*

The Wireless Channel

Multipath propagation has historically been regarded as an **impairment** because it causes signal fading.

To mitigate this problem, **diversity** techniques were developed over the years. Antenna diversity is a widespread form of diversity.

*Information theory has shown that with **multipath propagation, multiple antennas** at both transmitter and receiver can establish essentially **multiple parallel channels** that operate **simultaneously**, on the same frequency band at the same total radiated power.*

Spectral Efficiency Limits: Shannon Bound

- The information-theoretic capacity of single-antenna links is **limited** by the link's **signal to noise ratio** according to Shannon's celebrated formula
- Each extra bps/Hz requires roughly a **doubling** of the Tx power (to go from 1 bps/Hz to 11 bps/Hz, the Tx power must be increased by ~1000 times!)

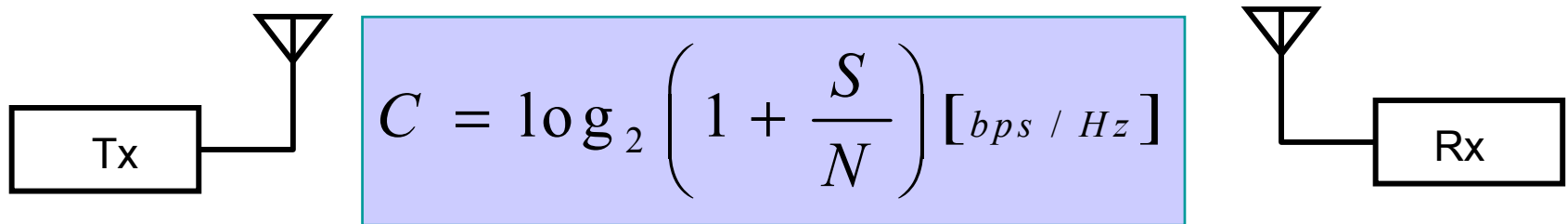

*C. Shannon
Bell Labs Technical Journal, 1948*

“It is dangerous to put limits on wireless”

Guglielmo Marconi, 1932

Multiple antenna links

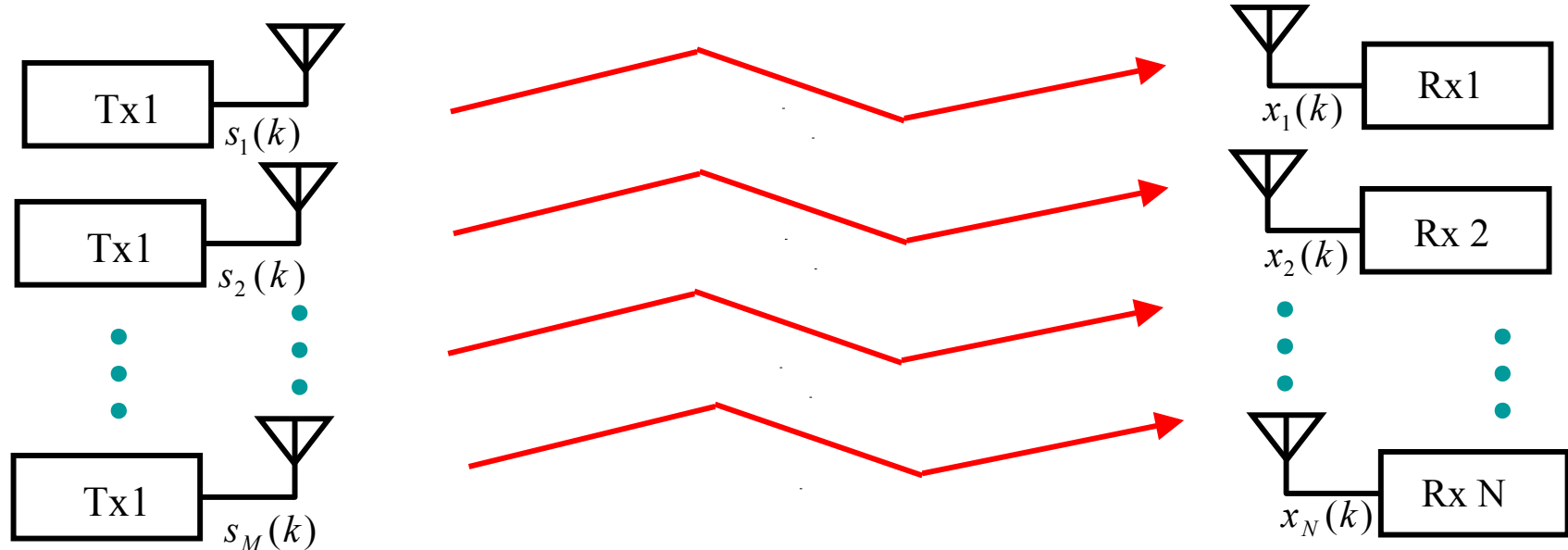

- Keeping the game fair: total Tx power should remain the same
- Questions: (1) How should we transmit from the different antennas?
(2) What is the corresponding capacity?
(3) How should the receiver operate?

Parallel Channels

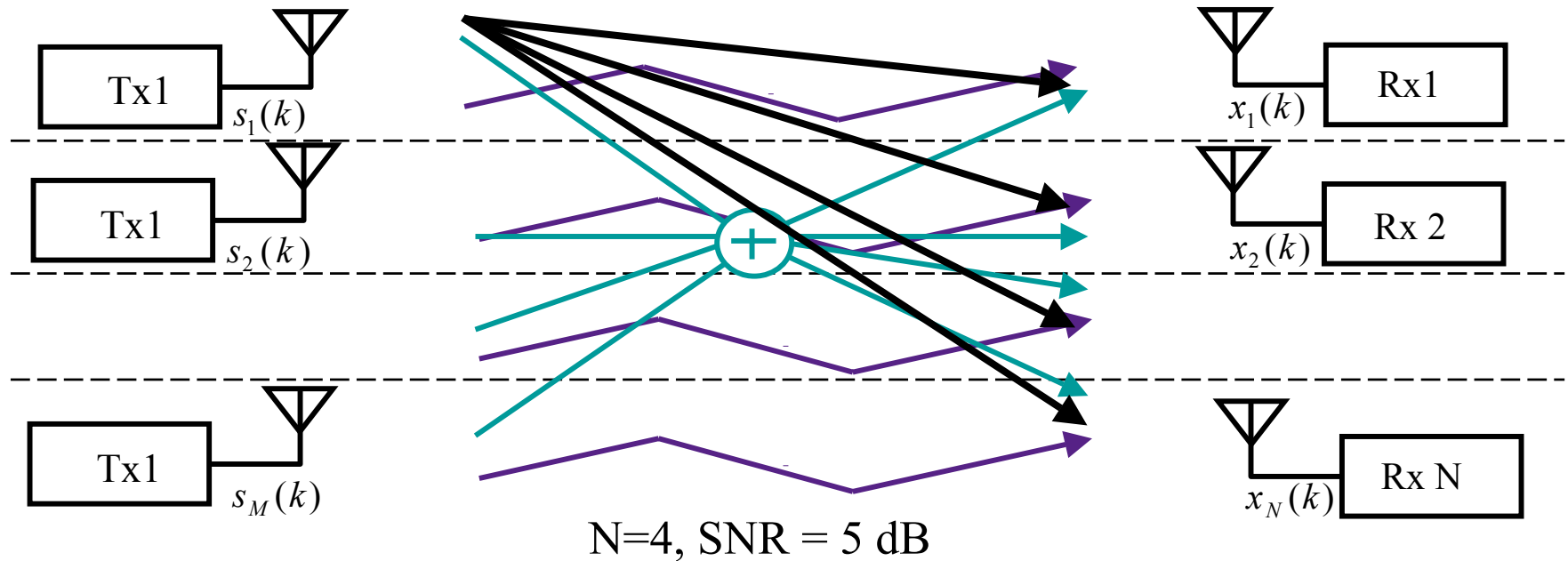

(N,N) Key-hole, $C = \log_2(1+\text{SNR})$

N (1,1) parallel channels $C = N \log_2(1+\text{SNR}) = 8.2$ b/sec/Hz

N (1,N) parallel channels with diversity $C = N \log_2(1+\text{SNR}) = 15$ b/sec/Hz

Capacities for Canonical Cases

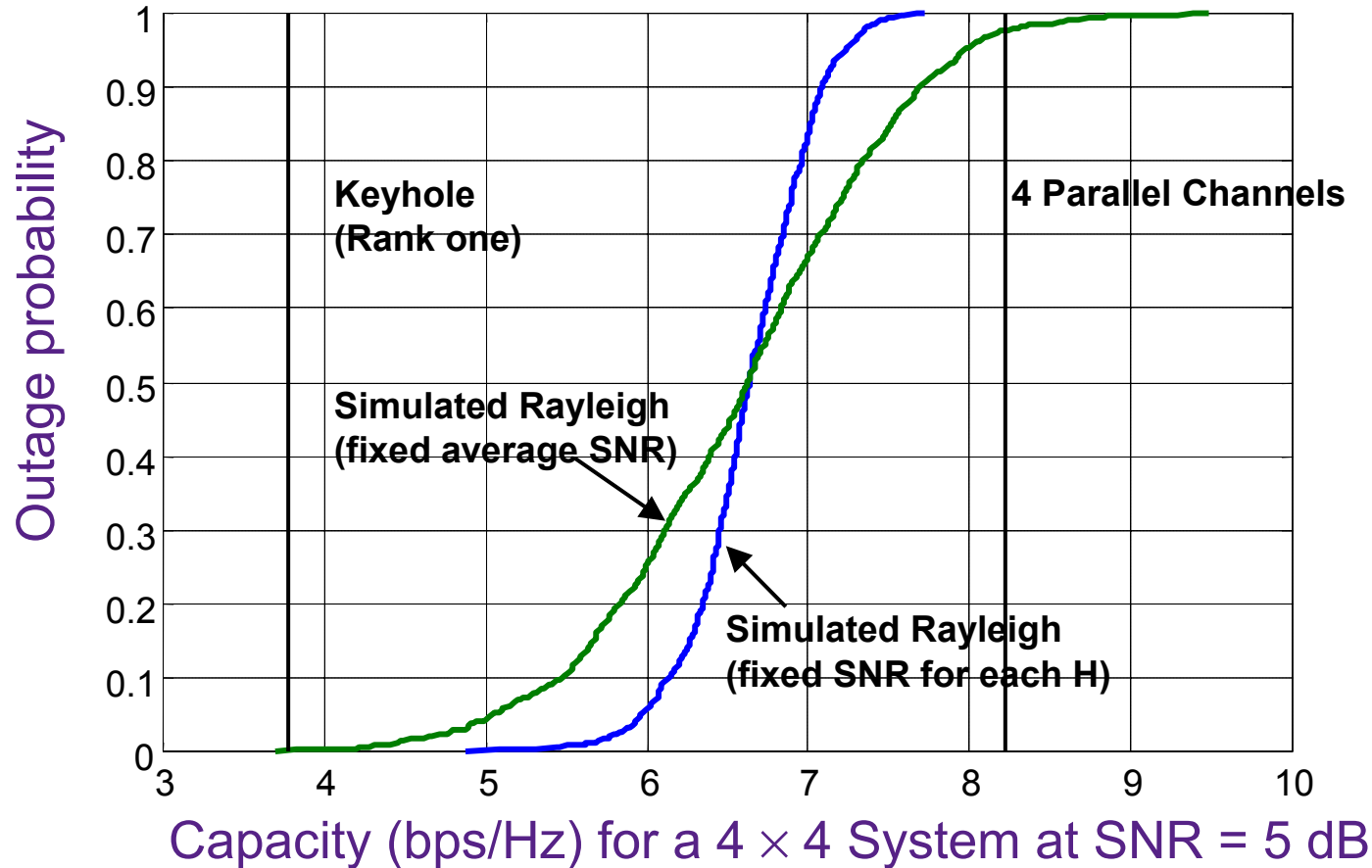

Efficiency Limits with a Single Array

- A single array provides diversity against fading
- Slow logarithmic growth of the bandwidth efficiency limit

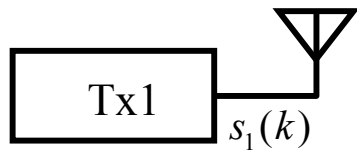

$$C = \log_2 \left(1 + \frac{S}{N} \right)$$

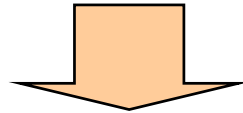

$$C = \log_2 \left(1 + M \frac{S}{N} \right)$$

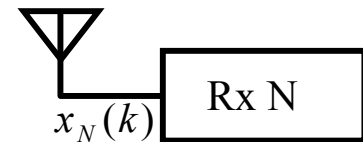
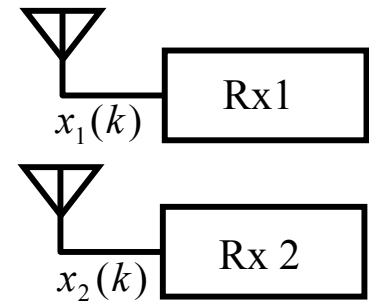

Lifting the Limits with Dual Arrays

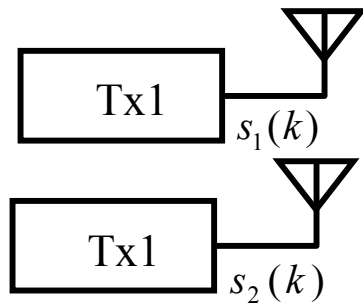

$$C = \log_2 \left(1 + \frac{S}{N} \right)$$

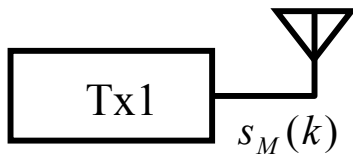
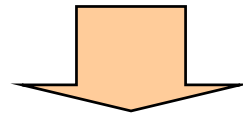
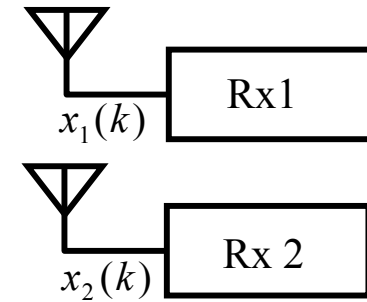

$$C \approx M \log_2 \left(1 + \frac{S}{N} \right)$$

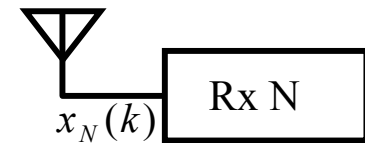

number of antennas in the smaller of the transmit and receive arrays

Extending the Limits with Multiple Antennas

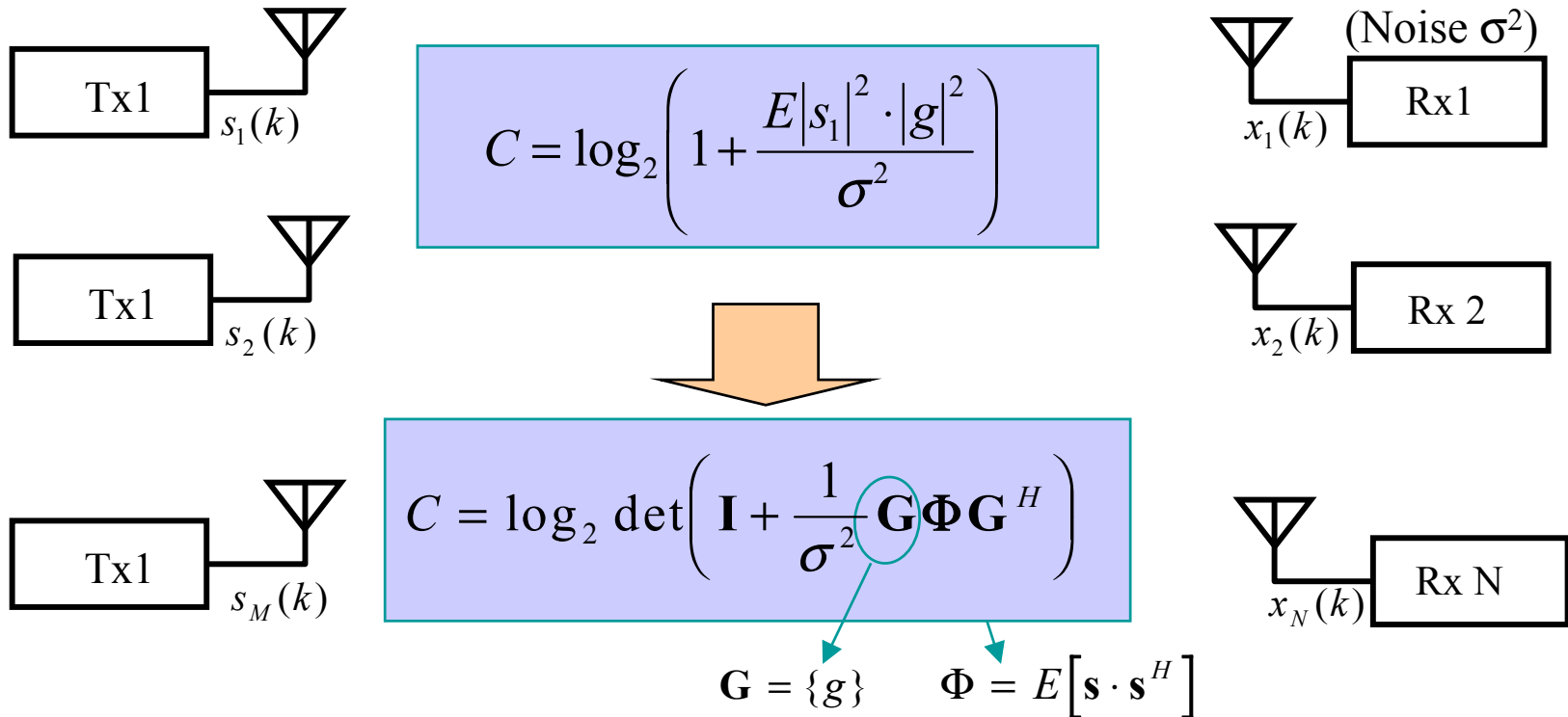

- Total Transmit Power Held Constant -

Extending The Limits: Frequency selective case

$$C = \frac{1}{B} \int_B \log_2 \det \left[\mathbf{I} + \mathbf{G}(f) \Phi(f) \mathbf{G}^+(f) \mathbf{K}^{-1}(f) \right] df$$

- F: Covariance matrix of transmit signal ($n_T \times n_T$)**
- G: Channel response matrix, not normalized ($n_R \times n_T$)**
- K: Covariance matrix of impairment ($n_R \times n_R$)**
- B: Bandwidth.**

Only requirement: that the impairment be Gaussian.

With flat fading, the integration and its averaging effects disappear

$$C = \log_2 \det \left[\mathbf{I} + \mathbf{G} \Phi \mathbf{G}^+ \mathbf{K}^{-1} \right]$$

Propagation Model and Array Structure

When entries of \mathbf{G} are independent, open-loop capacity is maximized by transmitting Gaussian signals with covariance

$$\Phi = \frac{P}{n_T} \mathbf{I}$$

with P the total radiated power.

If entries of \mathbf{G} have same variance (g), define unit-variance normalized channel matrix \mathbf{H} so that

$$C = \log_2 \det \left[\mathbf{I} + \frac{P}{n_T} g \mathbf{H} \mathbf{H}^+ \mathbf{K}^{-1} \right]$$

Noise-limited Open Loop Capacity

When the impairment consists exclusively of thermal noise:

$$\mathbf{K} = \sigma^2 \mathbf{I}$$

σ^2 : noise power per receive antenna.

$$C = \log_2 \det \left[\mathbf{I} + \underbrace{\left(\frac{P g}{\sigma^2} \right)}_{\text{SNR}} \frac{1}{n_T} \mathbf{H} \mathbf{H}^+ \right]$$

Different levels of randomness in the channel:

- **Large-scale randomness distance dependent , shadowing, etc. Absorbed into SNR, which can be regarded as deterministic within a local area.**
- **Small-scale randomness cause by multipath and contained within H.**

Asymptotic Capacities

Increasing...

...**SNR** with symmetric arrays, $n_T = n_R = n$

$$C = n \log_2 \left(\frac{\text{SNR}}{e} \right)$$

...**transmitters, n_T** , with n_R constant

$$C = n_R \log_2 (1 + \text{SNR})$$

...**receivers, n_R** , with n_T constant

$$C = n_T \log_2 \left(1 + \frac{n_R}{n_T} \text{SNR} \right)$$

Capacity Scaling

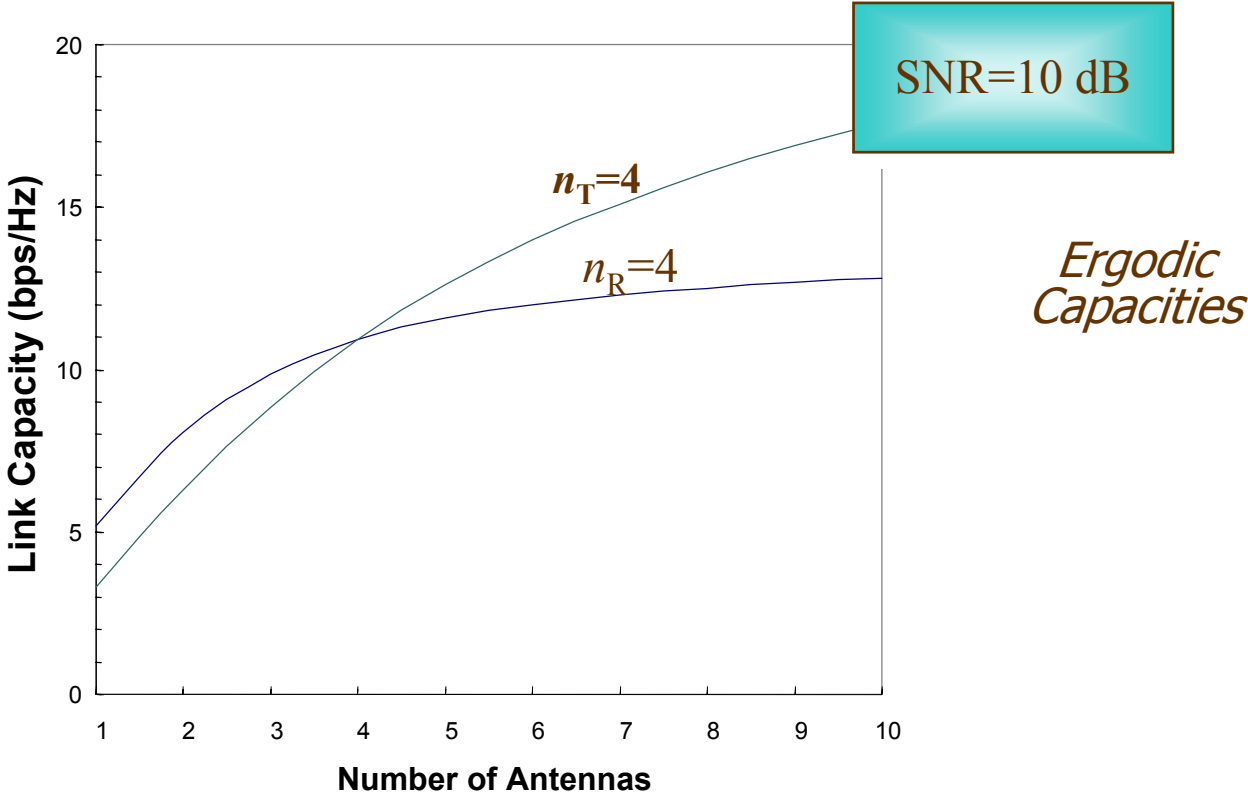

Bandwidth Efficiency Improvement: BLAST Versus Diversity

Efficiency achieved with 90% probability in bps/Hz or, equivalently, in Mbps/MHz

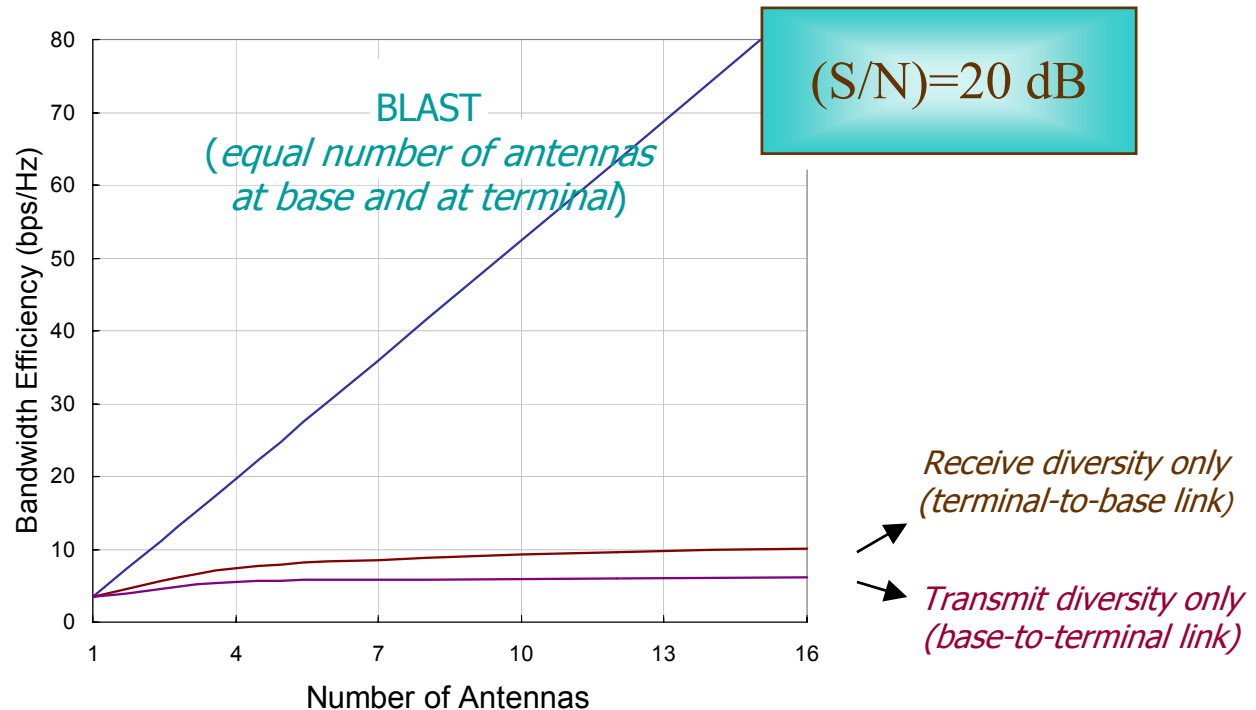

Basic Assumptions

To evaluate the levels of spectral efficiency attainable with some high probability, let us assume --for the time being-- some idealized conditions. We will revisit these assumptions later ...

Single-user link

AWGN limited (no co-channel interference)

Narrowband

Channel perfectly known to receiver

Rich multipath conditions

perfectly known at the receiver.

Open-loop operation. Only long-term information (defined as that which varies slowly with respect to the fading rate) available to the transmitter.

Terminal antennas: uncorrelated.

Base station antennas: coherent if closely spaced, uncorrelated if widely spaced. (limiting cases.)

Focus on downlink, most of the results apply to uplink as well.

Base-to-Terminal Link Analysis

- How does BLAST enhance the theoretically achievable data rates in a case of practical interest ? Let us look at how fast information can be transferred from a base station down to a mobile user in the following conditions:
 - Bandwidth $B=5$ MHz
 - Power $P_T=10$ W
 - No interference from other users (best possible scenario)
 - Sector antennas at base station
 - Omnidirectional antennas at terminal

Theoretical Performance

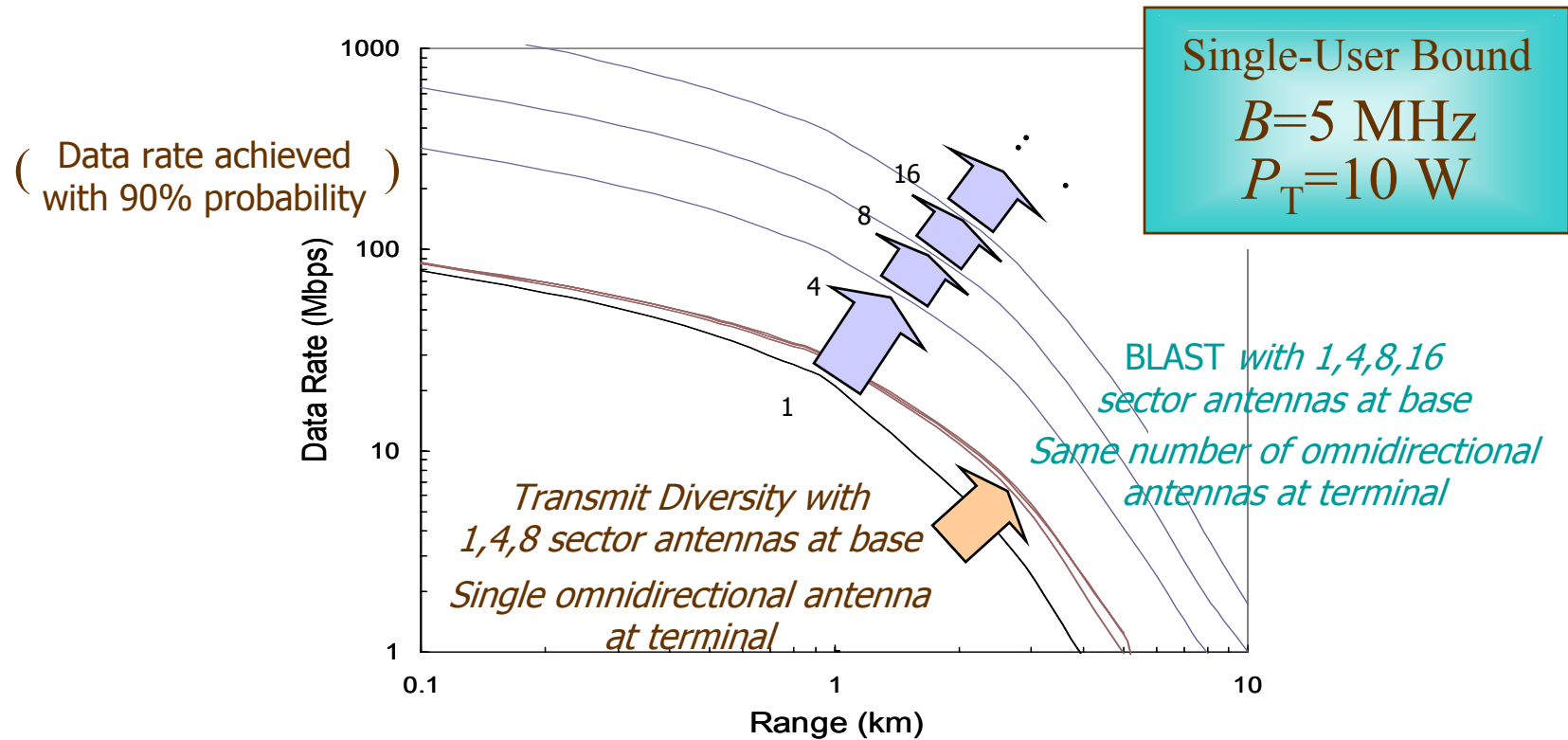

Narrow-band signal model

- Different sub-stream of data is transmitted from each antenna, narrow-band channel:

$$\mathbf{x}(k) = \mathbf{H}\mathbf{s}(k) + \mathbf{n}(k)$$

where:

- \mathbf{X} is $N \times 1$, \mathbf{H} is $N \times M$ and $\mathbf{s} = [s_1 \Lambda s_M]^T$ is $M \times 1$
 - s_m is zero-mean with variance P_t / M
 - P_t is total average transmitted power from all antennas
 - h_{mn} is independent Rayleigh faded with unit variance
 - v_n is Gaussian, zero-mean, of variance σ^2
 - ρ is average SNR at any Rx antenna
-
- Shannon capacity: $C_{M,N} = \log_2 \det(\mathbf{I}_N + (\rho / M)\mathbf{H}\mathbf{H}^H)$ bps/Hz
[G. Foschini '96]

Bell-laboratories LAYERed Space-Time

- With dual arrays bandwidth efficiency growth is **linear** with the number of antennas. This is in contrast with the logarithmic growth obtained with a single array (conventional diversity).
- To exploit this potential, Foschini and Golden proposed a layered space-time architecture that was baptized as **BLAST**.
- In **BLAST**, multiple data streams are transmitted **simultaneously** and on the same frequency using a transmit array. Those different streams can be separated and successfully decoded at the receiver using another array.
- **The total transmit power is preserved** irrespective of the number of transmit antennas ..! Hence, there is no increase in the amount of interference caused to other users.
- The transmitter needs no information about the channel, which eliminates the need for fast feedback links -- very attractive for mobile systems.

BLAST transceiver architecture

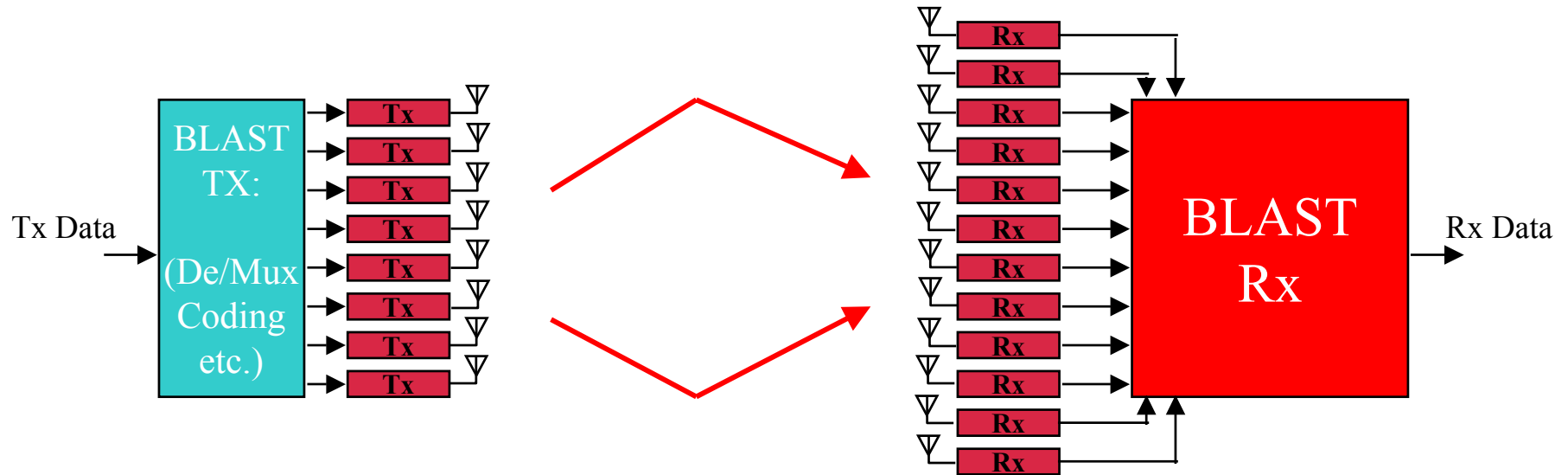

- Different data sub-streams are transmitted from different antennas
- Signal processing at the receiver attempts to separate the received signals

D-BLAST transmission architecture

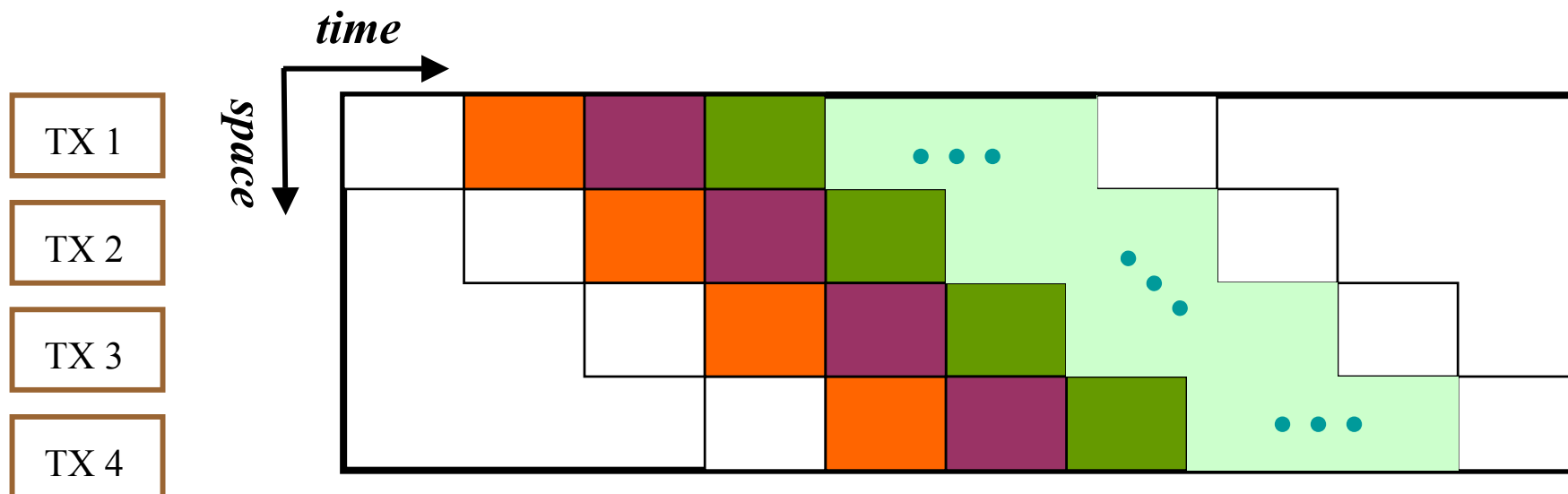

Theoretically achieves log-det capacity with appropriate Rx processing

Practical caveats:

- lost triangles
- high complexity
- coding constraints

V-BLAST transmission architecture

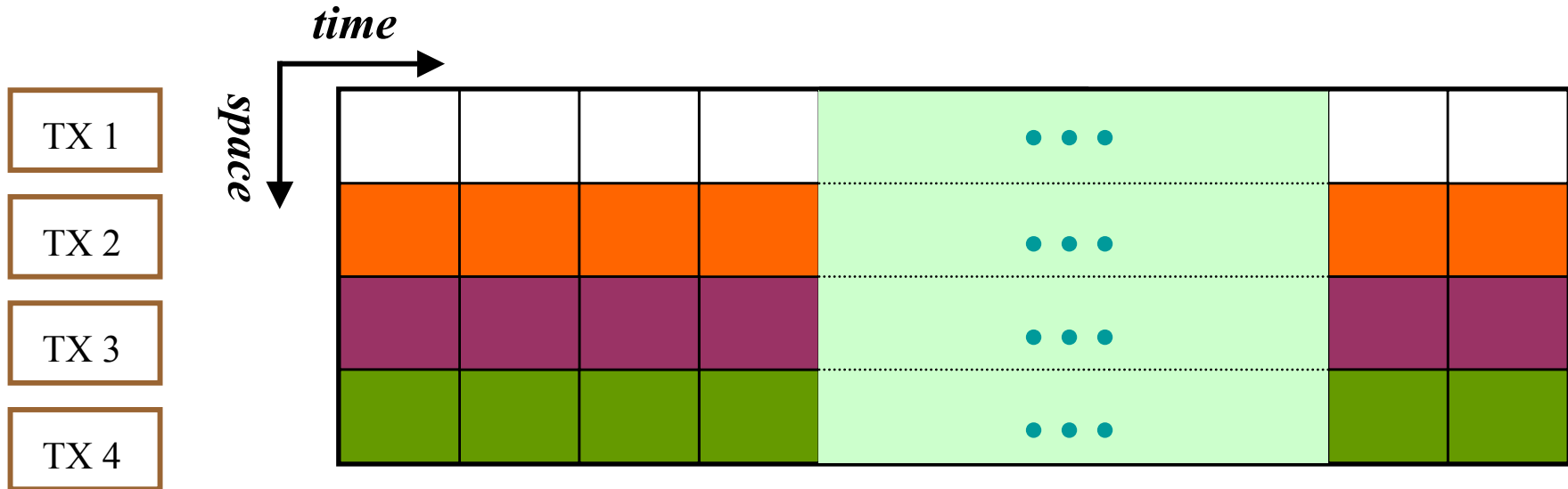

Achieves far lower capacity than the log-det bound

Practical advantages:

- no lost triangles
- lower complexity
- simple 1-D codecs

Narrow-band processing options

- Linear receivers:

$$\mathbf{z}(k) = \mathbf{W}^T(k)\mathbf{x}(k)$$

- Decorrelating (**ZF**) receiver: $\mathbf{W}(k) = \mathbf{H}^\dagger = \mathbf{H}^* (\mathbf{H}^T \mathbf{H}^*)^{-1}$

- Maximum SNR (**MMSE**) receiver: $\mathbf{W}(k) = \left(\mathbf{H}^* \mathbf{H}^T + \frac{M}{\rho} \mathbf{I}_N \right)^{-1} \mathbf{H}^*$

- Non-linear receivers:

- Similarly to **Multi-User Detection** (MUD), a number of non-linear alternatives range from successive interference cancellation to joint maximum likelihood receivers
- **V-BLAST** Rx: an appealing architecture based on **successive intf. Cancellation** (SIC)

V-BLAST

A **V-BLAST** receiver extracts the various data streams using a ZF or MMSE filter with ordered successive interference cancellation

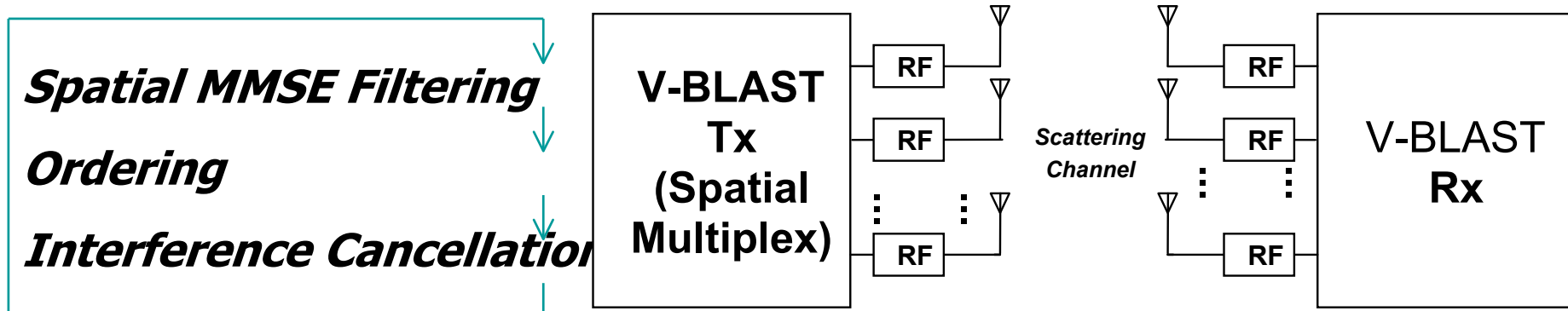

V-BLAST (DFE-type) receiver

- Sequential processing based on successive nulling+cancellation
- Let $\{k_1, \dots, k_M\}$ denote the order into which the sub-streams are detected

– Sub-stream k_1

Optimal Ordering:

$$\text{SNR}_{k_1} > \text{SNR}_{k_2} > \dots > \text{SNR}_{k_M}$$

– Sub-stream k_2



– Sub-stream k_M

Nulling:

$$z_{k_1}(k) = W_{k_1}^T \mathbf{x}(k)$$

Slicing:

$$\hat{s}_{k_1}(k) = \text{dec}(z_{k_1}(k))$$

Cancelling:

$$\mathbf{x}^1(k) = \mathbf{x}(k) - \hat{s}_{k_1}(k) \mathbf{H}(:, k_1)$$

Nulling:

$$z_{k_2}(k) = W_{k_2}^T \mathbf{x}^1(k)$$

Slicing:

$$\hat{s}_{k_2}(k) = \text{dec}(z_{k_2}(k))$$

Cancelling:

$$\mathbf{x}^2(k) = \mathbf{x}^1(k) - \hat{s}_{k_2}(k) \mathbf{H}(:, k_2)$$

Nulling:

$$z_{k_M}(k) = W_{k_M}^T \mathbf{x}^{M-1}(k)$$

Slicing:

$$\hat{s}_{k_M}(k) = \text{dec}(z_{k_M}(k))$$

Bell-Laboratories LAYERed Space-Time

- Under these idealized conditions, the link spectral efficiency growth is (asymptotically) **linear** with the number of antennas, with the **slope** determined by the average **SNR**. This is in contrast with the **logarithmic** growth obtained through **diversity**.
- To exploit this potential, Foschini and Golden proposed two layered space-time architectures: Diagonal BLAST (**D-BLAST**) and Vertical BLAST (**V-BLAST**) in which **multiple data streams** are transmitted **simultaneously** on the **same frequency band** using a transmit array. Those different streams can be separated and successfully decoded using a receive array. The total **transmit power is preserved** irrespective of the number of transmit antennas. There is **no increase in the interference** caused to other users.
- **Shannon limit can be approached with D-BLAST**, and even attained, although with significant **complexity**.
- **V-BLAST** is much simpler and still attains a hefty portion of the Shannon spectral efficiency. Every antenna radiates an independently encoded equal-rate data stream. A V-BLAST receiver bridges the gap between adaptive antenna and multiuser detection techniques.
- The **transmitter** needs **no channel information**, which eliminates the need for fast feedback links -- **very attractive for mobile systems**.

BLAST advantage over Rx Diversity

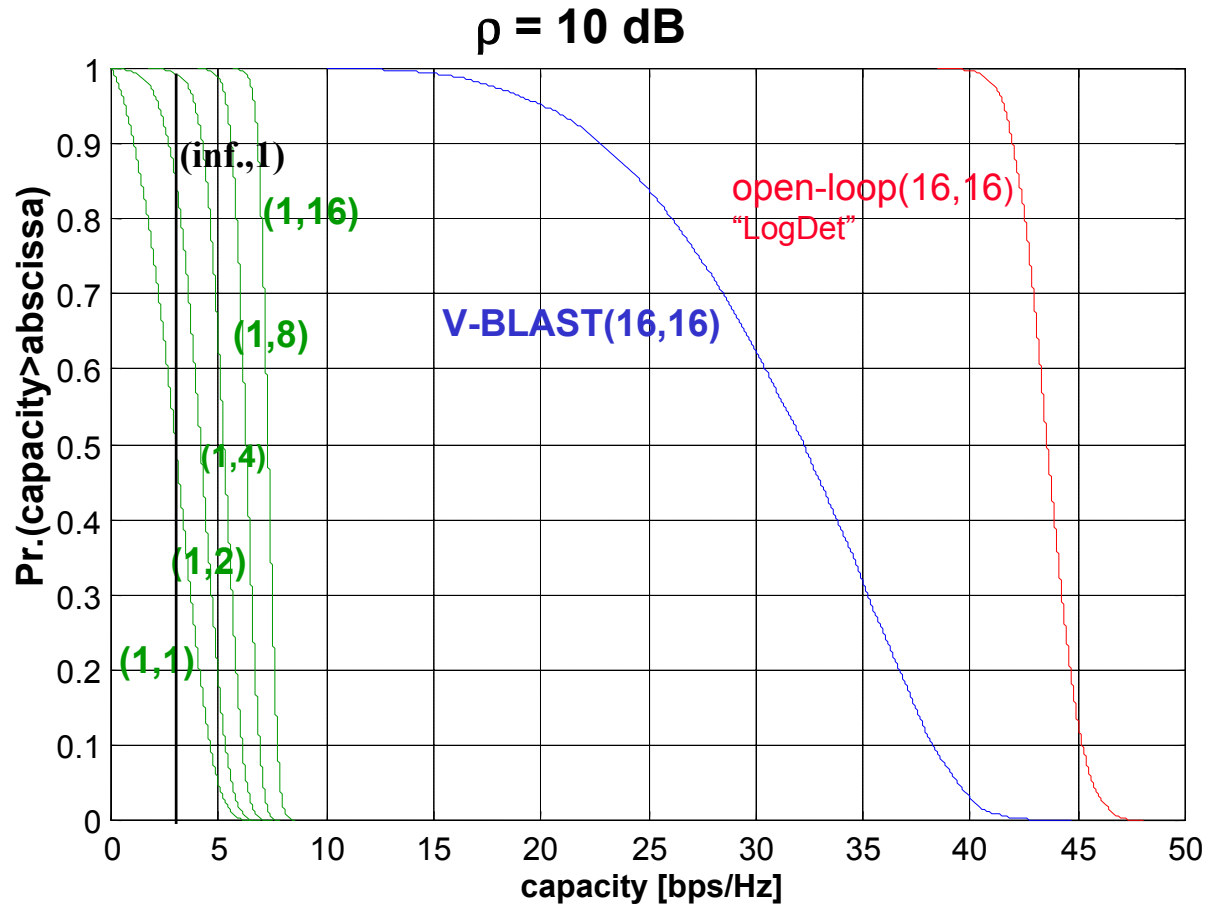

Closed-loop vs. Open-loop

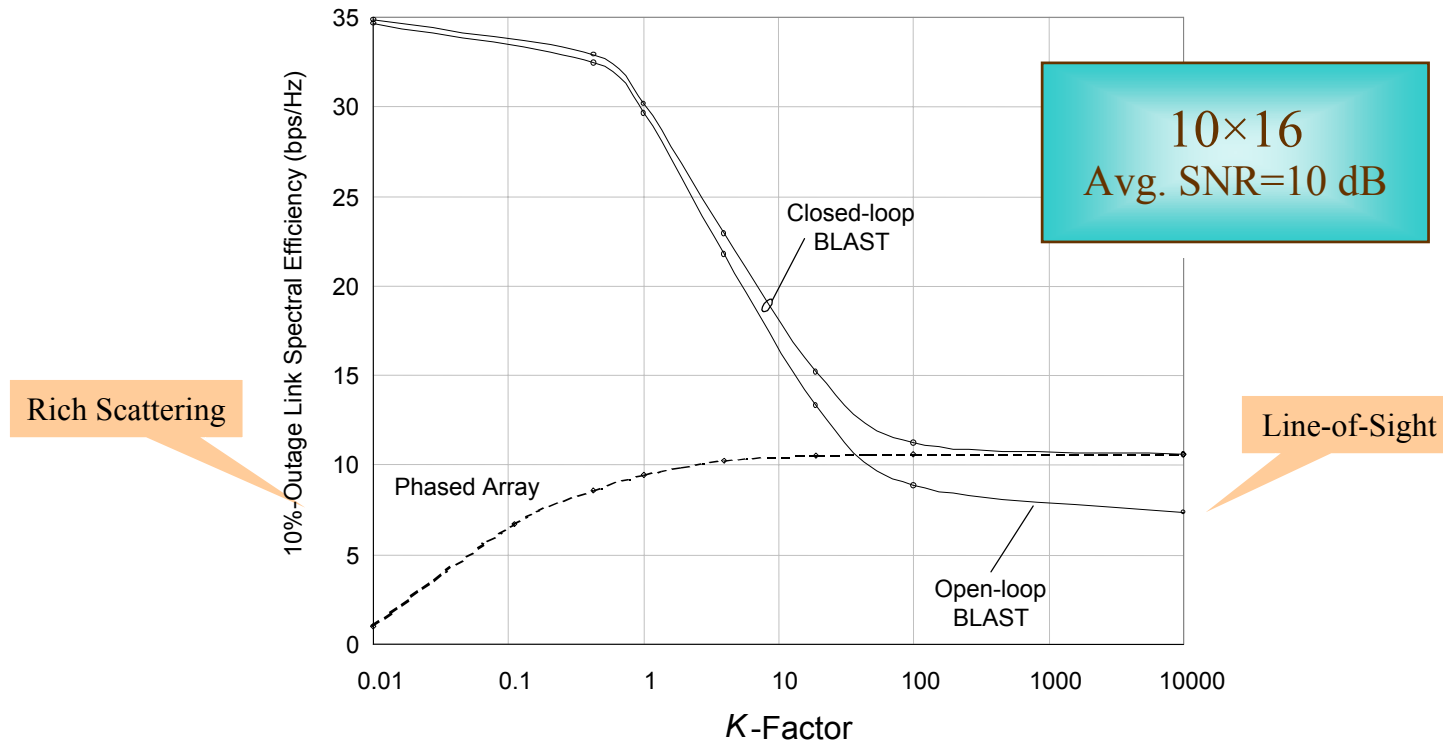

Open and closed loop BLAST are close for $K < 10$: Open-loop BLAST is very *robust*.

With little scattering, closed-loop BLAST, forms a beam (Phased Array),

Open-loop BLAST insists on M different modes. The difference in spectral efficiency is only moderate.

Water pouring over eigen modes is optimal in AWGN. Requires fast CSI feedback. Practical for FWL and portable

Generalized Closed-loop BLAST

Generalized BLAST optimal with spatially colored co-channel Interference

Obtains the link eigenmodes in the presence of non-white interference.

Maximizes the link spectral efficiency.

Includes all other forms of BLAST as particular cases.

A “fast” feedback with information on the **channel and the interference statistics** is required.

The Best H Matrix, *identity*

supremum = "parallel interferenceless beam steering" = all equal eigen values

Important as a calibration tool for normalizing transmitter and receiver gains

Capacity for a 4x4 system for H = identity
for various measurement SNR values, p_H

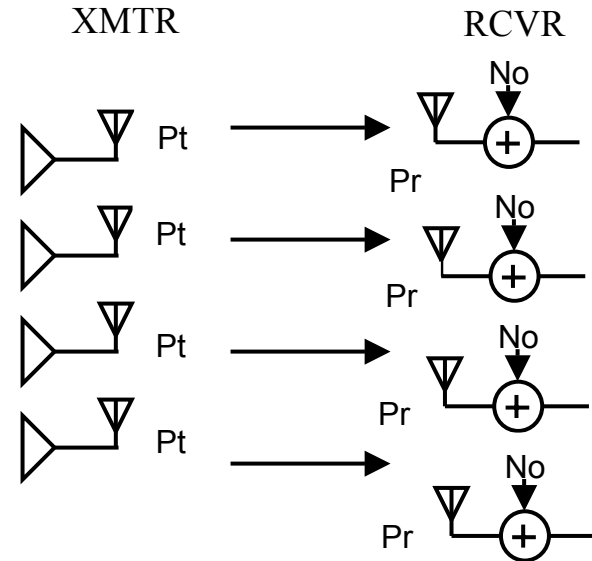
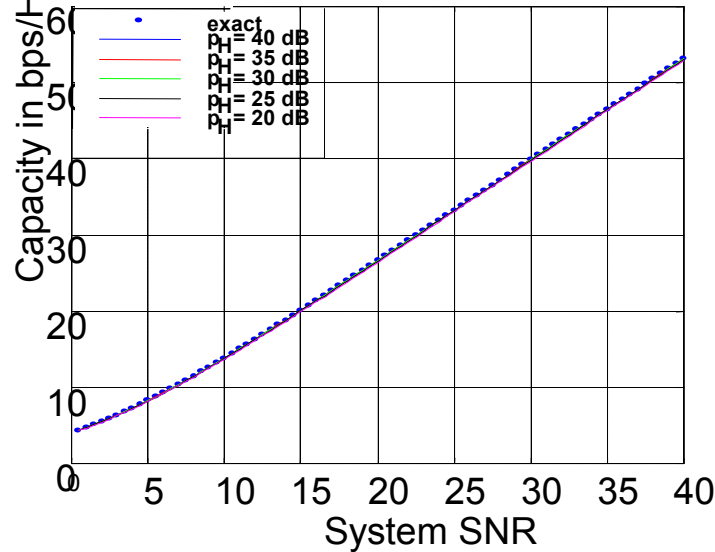

$$H = \begin{bmatrix} \sqrt{N} & 0 & \dots & 0 \\ 0 & \sqrt{N} & \dots & 0 \\ \dots & \dots & \dots & \dots \\ 0 & 0 & \dots & \sqrt{N} \end{bmatrix} \Rightarrow E[|h_{ij}|^2] = 1, C = N \log_2(1 + SNR)$$

M = N

$$Pr = g * Pt$$

$$SNR = g * Pt * 1/No$$

The Worst H Matrix, *dyad or Keyhole*

"keyhole" = receiver diversity only = one eigen value only

Important as a calibration tool due to sensitivity of measured versus system SNR, sanity check so that bench and field tests do not overly estimate BLAST capacity.

Capacity for a 4x4 system for H = all ones
for various measurement SNR values, p_H

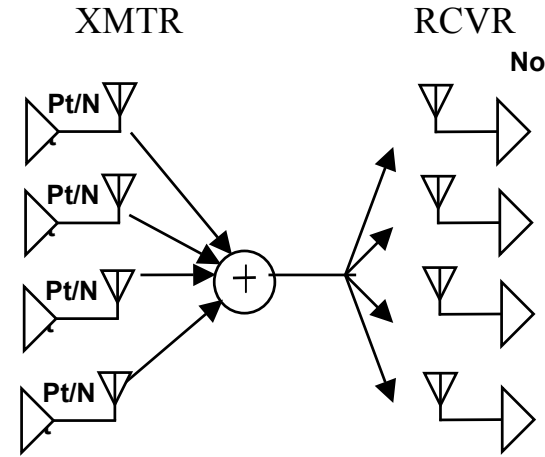
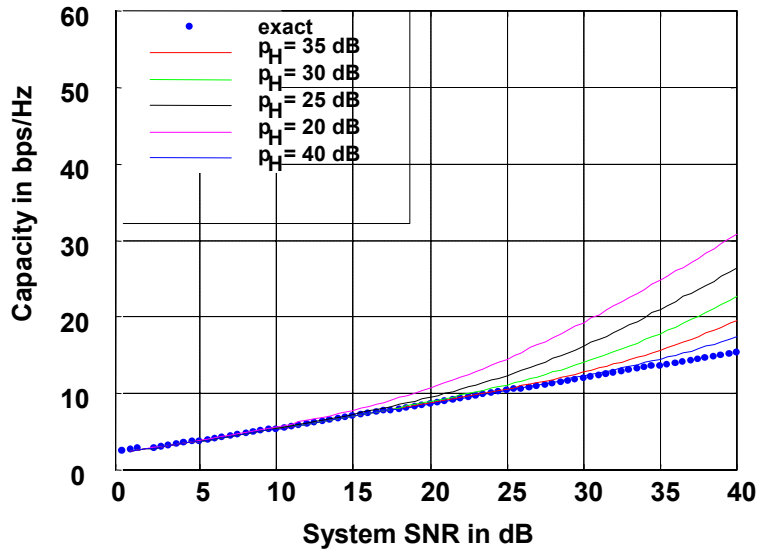

$$P_r = g * P_t / N_t$$

$$SNR = g * P_t * N_r / N_t * 1/N_o$$

$$H = \begin{bmatrix} 1 & 1 & \dots & 1 \\ 1 & 1 & \dots & 1 \\ \dots & \dots & \dots & \dots \\ 1 & 1 & \dots & 1 \end{bmatrix} \Rightarrow E[|h_{ij}|^2] = 1, C = \log_2(1 + N \cdot SNR)$$

M = N

Capacity vs. system size (M=N): keyhole

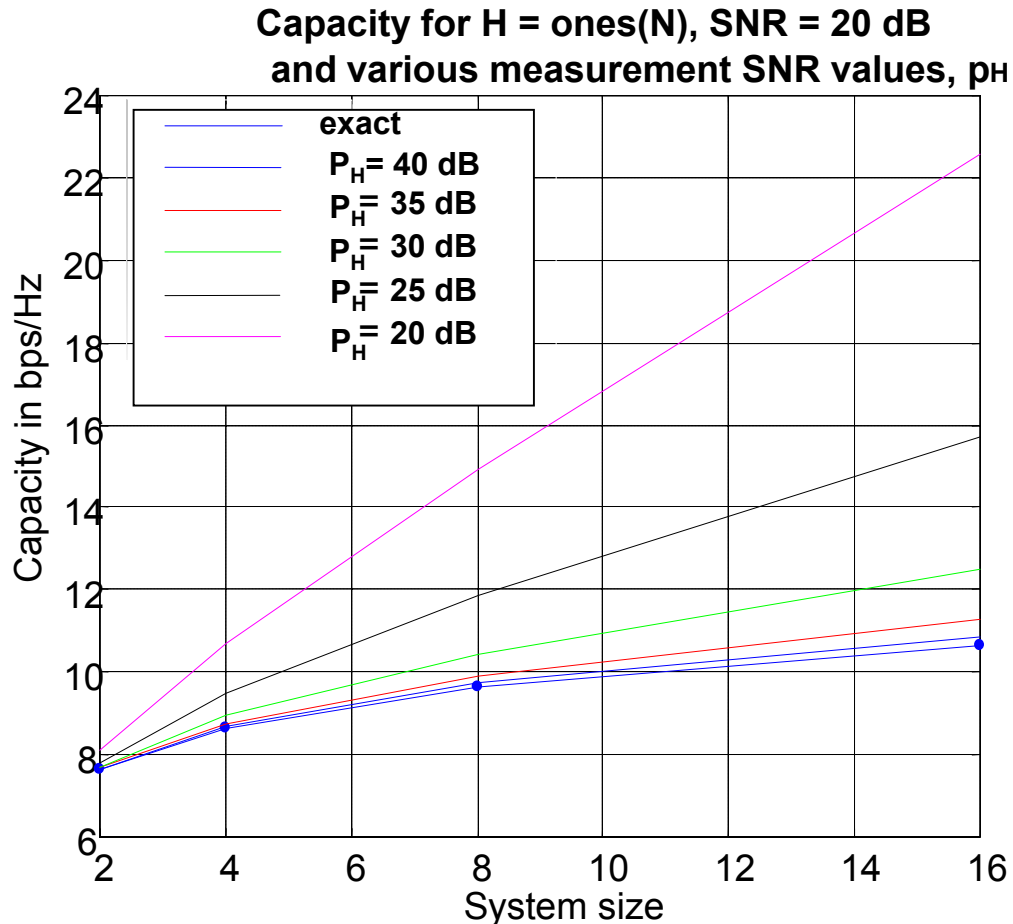

Propagation Modeling Theory

- **Background**
- **Capacity in correlated **Rayleigh** channels**
- **Singular Value Decomposition (**SVD**)**
- **Keyholes**
- **Waveguides**
- **Outdoor propagation**
- **Summary and conclusions**

Propagation Modeling

- **BLAST capacity** has been explored in
 - Statistical Rayleigh and Rician channels
 - Deterministic **Ray-Tracing** simulations (**WiSE**)
 - Abstract ray-tracing (1 and 2-ring scatterer models)
 - Deterministic over the ground plane propagation
 - Statistical Rayleigh channels with correlation due to limited angular spread
- What really happens **outdoors** and how is it connected to propagation conditions ?

Capacity in correlated complex Gaussian channels

- **Separable** correlation among transmit elements and receive elements:

$$C = \log_2 \left| \mathbf{I} + \frac{\rho}{n_T} \mathbf{H} \mathbf{H}^\dagger \right|, \quad \mathbf{H} = \sqrt{\Phi_R} \mathbf{H}_{iid} \sqrt{\Phi_T}$$

- \mathbf{H}_{iid} has complex Gaussian iid entries
- ρ is average SNR
- Φ_R is the covariance matrix of the receive elements
- Φ_T is the covariance matrix of the transmit elements

Representation of H using SVD

$$\mathbf{H}_{mn} = \mathbf{U}_{mm} \Lambda_{mn} \mathbf{V}_{nn}^*$$

- **U and V are orthogonal (unitary) matrices**
- **Λ is a diagonal matrix**

$$\mathbf{H} = \begin{pmatrix} u_{11} & u_{12} & u_{13} \\ u_{21} & u_{22} & u_{23} \\ u_{31} & u_{32} & u_{33} \end{pmatrix} \begin{pmatrix} \lambda_1 & 0 \\ 0 & \lambda_2 \\ 0 & 0 \end{pmatrix} \begin{pmatrix} v_{11}^* & v_{21}^* \\ v_{12}^* & v_{22}^* \end{pmatrix}$$

$$\mathbf{H} = \begin{pmatrix} u_{11} \\ u_{21} \\ u_{31} \end{pmatrix} \lambda_1 \begin{pmatrix} v_{11}^* & v_{21}^* \end{pmatrix} + \begin{pmatrix} u_{12} \\ u_{22} \\ u_{32} \end{pmatrix} \lambda_2 \begin{pmatrix} v_{12}^* & v_{22}^* \end{pmatrix}$$

Keyholes

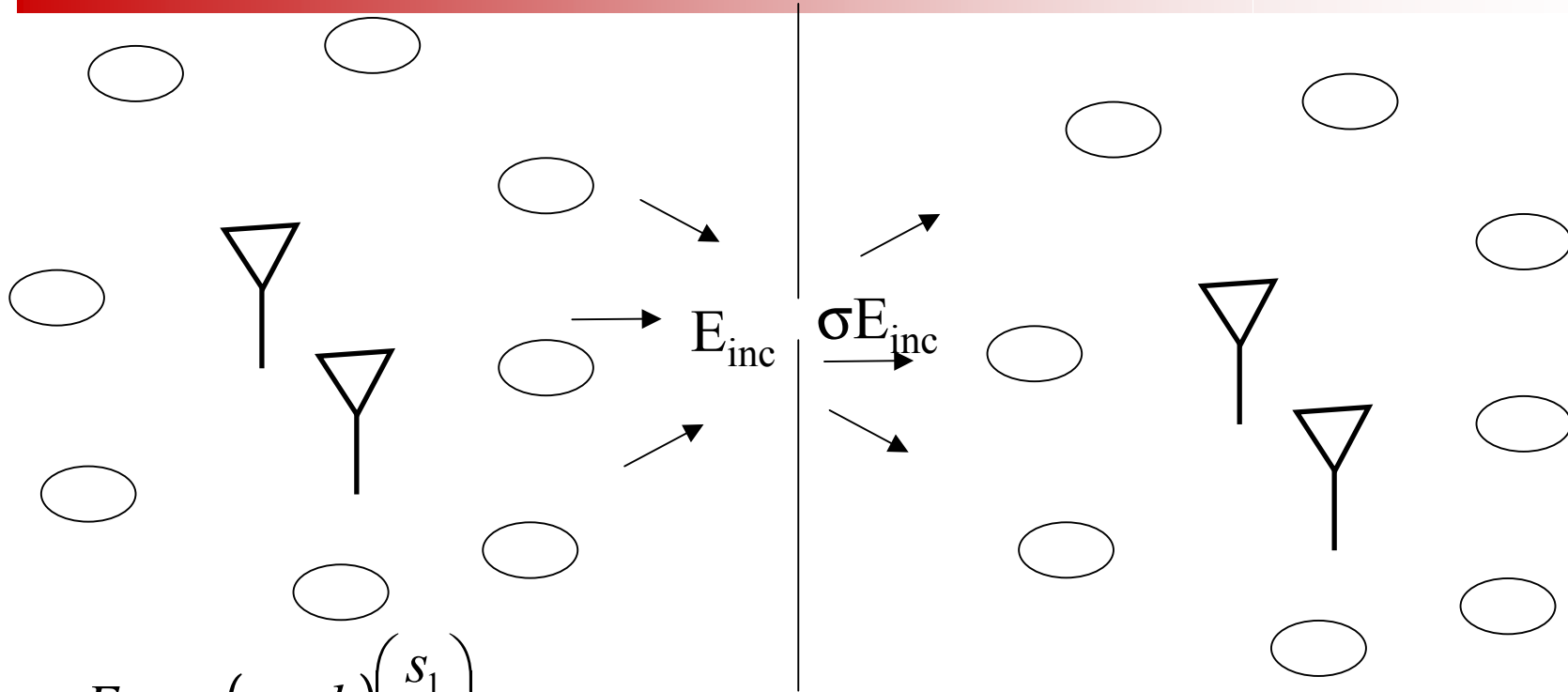

$$E_{inc} = \begin{pmatrix} a & b \end{pmatrix} \begin{pmatrix} s_1 \\ s_2 \end{pmatrix}$$

$$\mathbf{H} = \begin{pmatrix} c \\ d \end{pmatrix} \sigma \begin{pmatrix} a & b \end{pmatrix} = \sigma \begin{pmatrix} ca & cb \\ da & db \end{pmatrix}$$

$$E_{rec} = \begin{pmatrix} c \\ d \end{pmatrix} \sigma \begin{pmatrix} a & b \end{pmatrix} \begin{pmatrix} s_1 \\ s_2 \end{pmatrix}$$

Properties of keyholes

$$\mathbf{H} = \begin{pmatrix} c \\ d \end{pmatrix} \sigma \begin{pmatrix} a & b \end{pmatrix} = \sigma \begin{pmatrix} ca & cb \\ da & db \end{pmatrix}$$

- **a,b,c,d are independent, zero-mean complex Gaussian processes**
- $\langle h_{11} h_{12}^* \rangle = \langle ca c^* b^* \rangle = \langle |c|^2 \rangle \langle a \rangle \langle b^* \rangle = 0$
- $\langle h_{ij} h_{kl}^* \rangle = 0$, unless $i=j$ and $k=l$
- **Note: Perfect decorrelation yet single degree of freedom.**
- h_{ij} is a product process of 2 complex Gaussian random processes

Properties of keyholes

- Received power $z=xy$, where x, y are exponential power distributions (Rayleigh processes) with mean power b

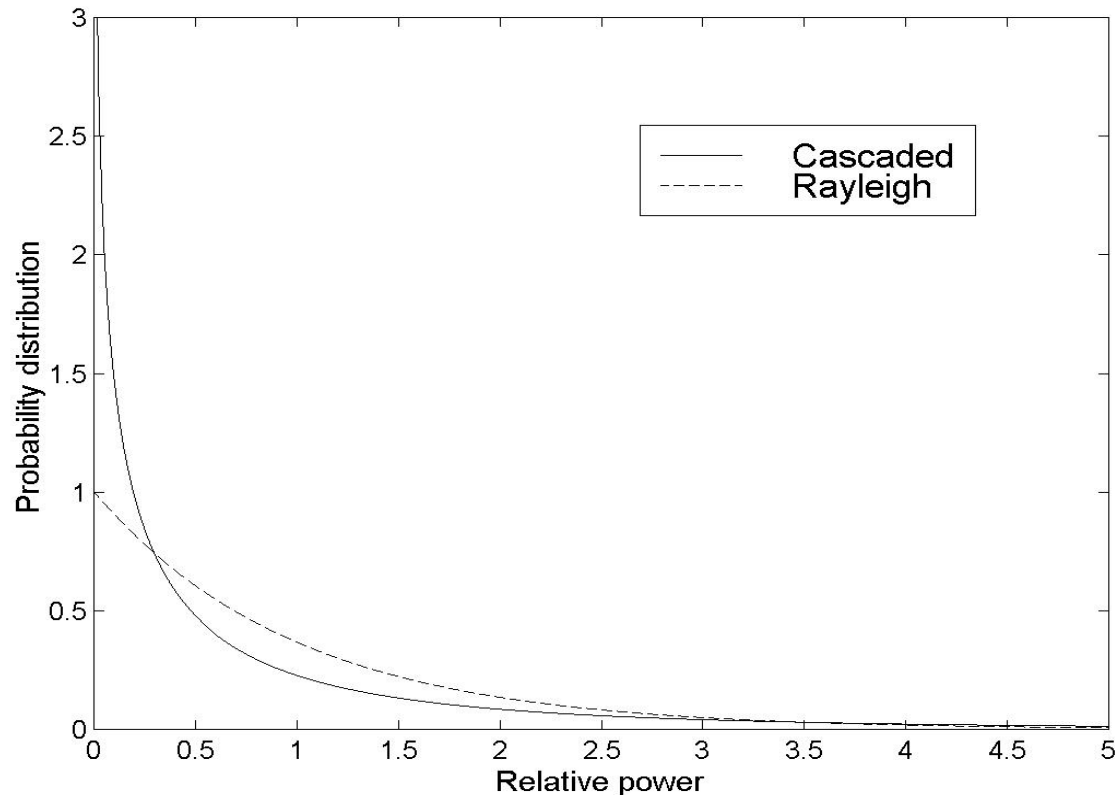

$$f(z) = \frac{2}{b^2} K_0\left(\frac{2\sqrt{z}}{b}\right)$$

Normal scattering

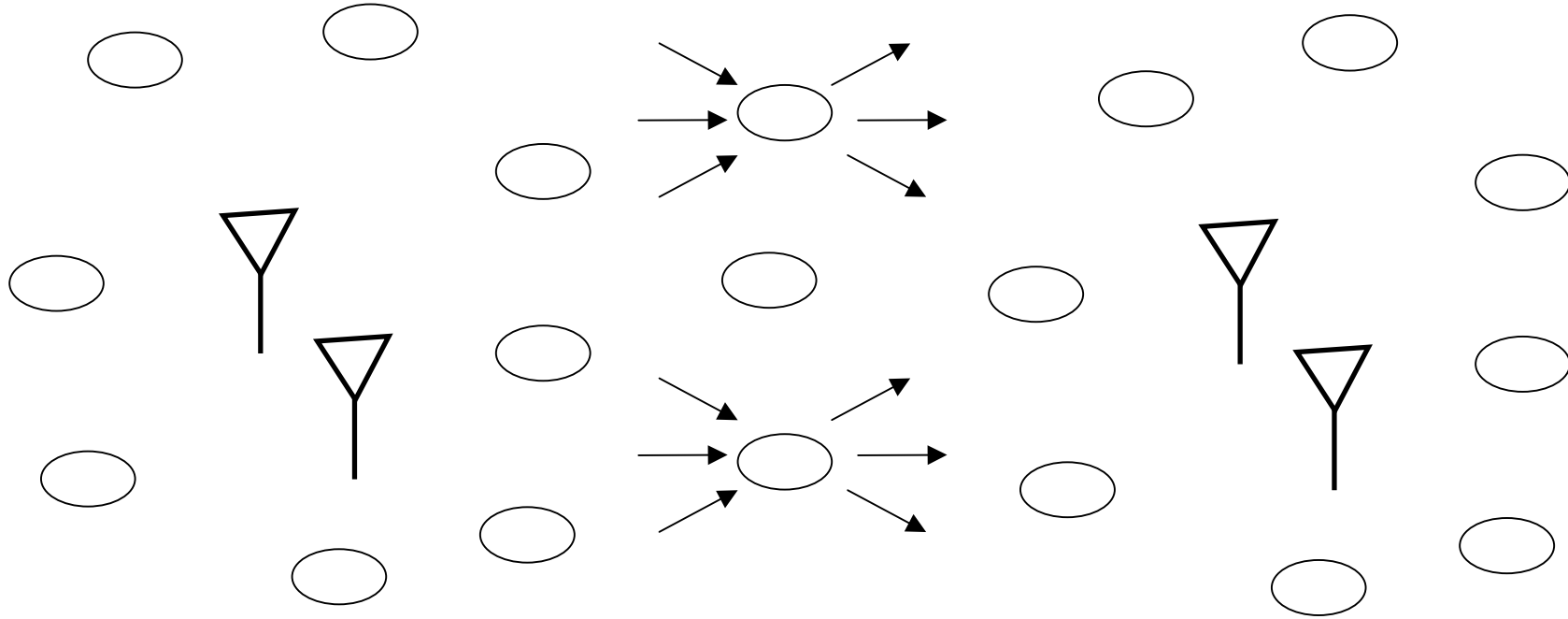

- Multiple scattering may be written as a sum over “keyhole” contributions, each a cascaded process of 2 complex Gaussian processes.
- For many “keyholes”, this sum is a complex Gaussian process according to the Central Limit Theorem

Implications of the presence of keyholes

- **Low capacity due to high correlation may be addressed by spreading antennas further.**
- **That strategy will not improve capacity in the presence of a keyhole.**
- **Possible indication of a keyhole: low correlation, yet low capacity.**
- **Keyholes provide a demanding test of the channel measurement system**

Waveguide modes

$$\nabla^2 h_{11} + k^2 h_{11} = \delta(\underline{r}_1 - \underline{t}_1)$$

$$h_{11} = \sum_k \phi_k(\underline{r}_1) \phi_k(\underline{t}_1) \frac{e^{i\beta_k x}}{2i\beta_k}$$

$$r_1 = \sum_m h_{1m} s_m = \sum_m \sum_k \phi_k(\underline{r}_1) \phi_k(\underline{t}_m) \frac{e^{i\beta_k x}}{2i\beta_k} s_m$$

$$\underline{\mathbf{r}} = \begin{pmatrix} r_1 \\ r_2 \\ \cdot \end{pmatrix} = \begin{pmatrix} \phi_1(r_1) & \phi_2(r_1) & \cdot \\ \phi_1(r_2) & \phi_2(r_2) & \cdot \\ \cdot & \cdot & \cdot \end{pmatrix} \begin{pmatrix} \frac{e^{i\beta_1 x}}{2i\beta_1} & 0 & \cdot \\ 0 & \frac{e^{i\beta_2 x}}{2i\beta_2} & \cdot \\ \cdot & \cdot & \cdot \end{pmatrix} \begin{pmatrix} \phi_1(t_1) & \phi_1(t_2) & \cdot \\ \phi_2(t_1) & \phi_2(t_2) & \cdot \\ \cdot & \cdot & \cdot \end{pmatrix} \begin{pmatrix} s_1 \\ s_2 \\ \cdot \end{pmatrix}$$

$$\mathbf{H} = \begin{pmatrix} \phi_1(r_1) \\ \phi_1(r_2) \\ \cdot \end{pmatrix} \frac{e^{i\beta_1 x}}{2i\beta_1} (\phi_1(t_1) \quad \phi_1(t_2) \quad \cdot) + \begin{pmatrix} \phi_2(r_1) \\ \phi_2(r_2) \\ \cdot \end{pmatrix} \frac{e^{i\beta_2 x}}{2i\beta_2} (\phi_2(t_1) \quad \phi_2(t_2) \quad \cdot) + \dots$$

Not SVD but **keyhole** still occurs when **1 mode dominates**.

Canonical outdoor environment

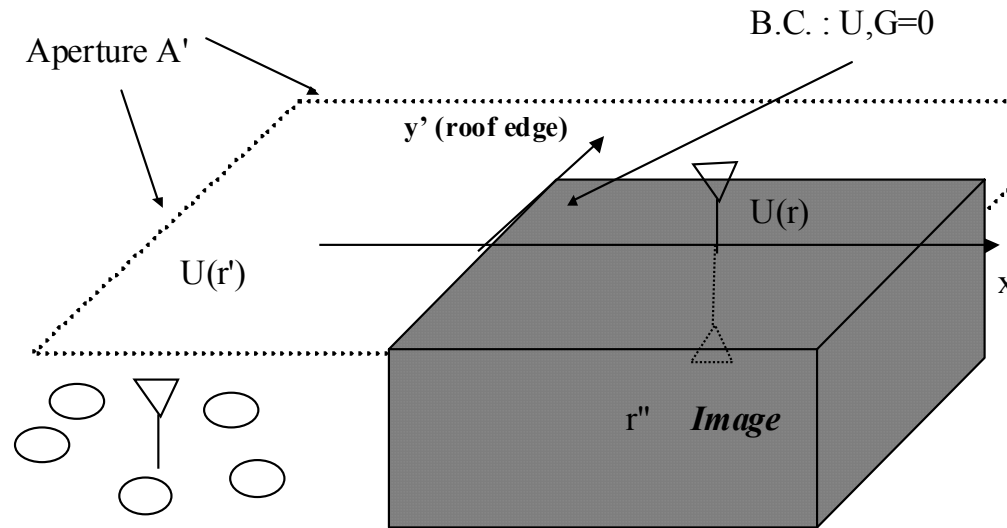

$$\nabla^2 U + k^2 U = 0$$

$$U(\underline{r}) = \iint \underline{dA}' \cdot (U \nabla G - G \nabla U)$$

$$G(\underline{r}') = \frac{e^{ik|\underline{r}-\underline{r}'|}}{4\pi|\underline{r}-\underline{r}'|} - \frac{e^{ik|\underline{r}''-\underline{r}'|}}{4\pi|\underline{r}''-\underline{r}'|}$$

Field at the base in the Fresnel approximation

$$R = \sqrt{(x-x')^2 + (y-y')^2 + (z-z')^2} \approx (x-x') + \frac{(y-y')^2 + (z-z')^2}{2x}$$
$$U(\underline{r}) = \frac{ize^{ikx}}{\lambda x^2} e^{ik\frac{(z^2+y^2)}{2x}} \int_{-\infty}^{\infty} dy' \int_{-\infty}^0 dx' U(x', y', 0) \exp\left(-ikx' + \frac{iky'^2}{2x} - \frac{iky y'}{x}\right)$$
$$U(\underline{r}) = \frac{ze^{ikx}}{\lambda x^2 k} e^{ik\frac{(z^2+y^2)}{2x}} \int_{-\infty}^{\infty} dy' U(0, y', 0) \exp\left(\frac{iky'^2}{2x} - \frac{iky y'}{x}\right)$$

Note: No dependence on z' coordinates.

Vertical base array

- H matrix may be factored:

$$\mathbf{H} = \begin{pmatrix} z_1 e^{ik \frac{z_1^2}{2x}} \\ z_2 e^{ik \frac{z_2^2}{2x}} \\ \bullet \end{pmatrix} \frac{e^{ikx}}{\lambda x^2 k} \left(\int_{-\infty}^{\infty} dy' G_1(0, y', 0) e^{\frac{ik(y-y')^2}{2x}} \quad \int_{-\infty}^{\infty} dy' G_2(0, y', 0) e^{\frac{ik(y-y')^2}{2x}} \quad \bullet \right)$$

- $G_i(0, y', 0)$ is the Green's function due to the source i , including all the street-level scattering
- H matrix is a dyad - single degree of freedom

Horizontally separated base array

$$\mathbf{H} = \frac{e^{ikx}}{\lambda x^2 k} z e^{ik \frac{z^2}{2x}} \begin{pmatrix} \int_{-\infty}^{\infty} dy' G_1(0, y', 0) e^{\frac{ik(y_1 - y')^2}{2x}} & \int_{-\infty}^{\infty} dy' G_2(0, y', 0) e^{\frac{ik(y_1 - y')^2}{2x}} & \bullet \\ \int_{-\infty}^{\infty} dy' G_1(0, y', 0) e^{\frac{ik(y_2 - y')^2}{2x}} & \int_{-\infty}^{\infty} dy' G_2(0, y', 0) e^{\frac{ik(y_2 - y')^2}{2x}} & \bullet \\ \bullet & \bullet & \bullet \end{pmatrix}$$

- Each receiver perceives each transmitter in a different way, thus no degeneracy
- Each $G_i(0, y', 0)$ is a zero-mean, complex Gaussian RV

Correlation

- Received field $U(\underline{r})$ is a linear functional of aperture field $U(\underline{r}')$. If $U(\underline{r}')$ is a gaussian process, so is $U(\underline{r})$.
- Mean and correlation describe the process completely.

$$\langle U(\underline{r}_1)U(\underline{r}_2)^* \rangle = \frac{z^2}{2\pi x^4} \int_{-\infty}^{\infty} \int_{-\infty}^{\infty} dy' dy'' \langle G_1(0, y', 0)G_1^*(0, y'', 0) \rangle e^{\frac{ik(y_1 - y')^2}{2x}} e^{-\frac{ik(y_2 - y'')^2}{2x}}$$

- Correlation at base is a linear functional of correlation at the aperture.

Incoherent line source at roof edge

- **Correlation at roof edge**

$$\rho = \langle G(0, y', 0) G^*(0, y'', 0) \rangle = \frac{4\pi^2}{k^2} I\left(\frac{y' + y''}{2}\right) \delta(y' - y'')$$

- **Incoherent intensity**

$$I(y) = \sqrt{\frac{1}{2\pi\sigma_y^2}} \exp\left(-\frac{y^2}{2\sigma_y^2}\right)$$

- **Correlation coefficient**

$$\rho(y_d) = \frac{\langle U(\underline{r}_1) U(\underline{r}_2)^* \rangle}{\sqrt{\langle |U(\underline{r}_1)|^2 \rangle \langle |U(\underline{r}_2)|^2 \rangle}} = \exp\left(-\frac{k^2 \sigma_y^2 y_d^2}{2x^2}\right)$$

- y_d is separation between base antennas

- $\sigma_y \sim$ street width ~ 30 meters

Correlation at the base station (1 km)

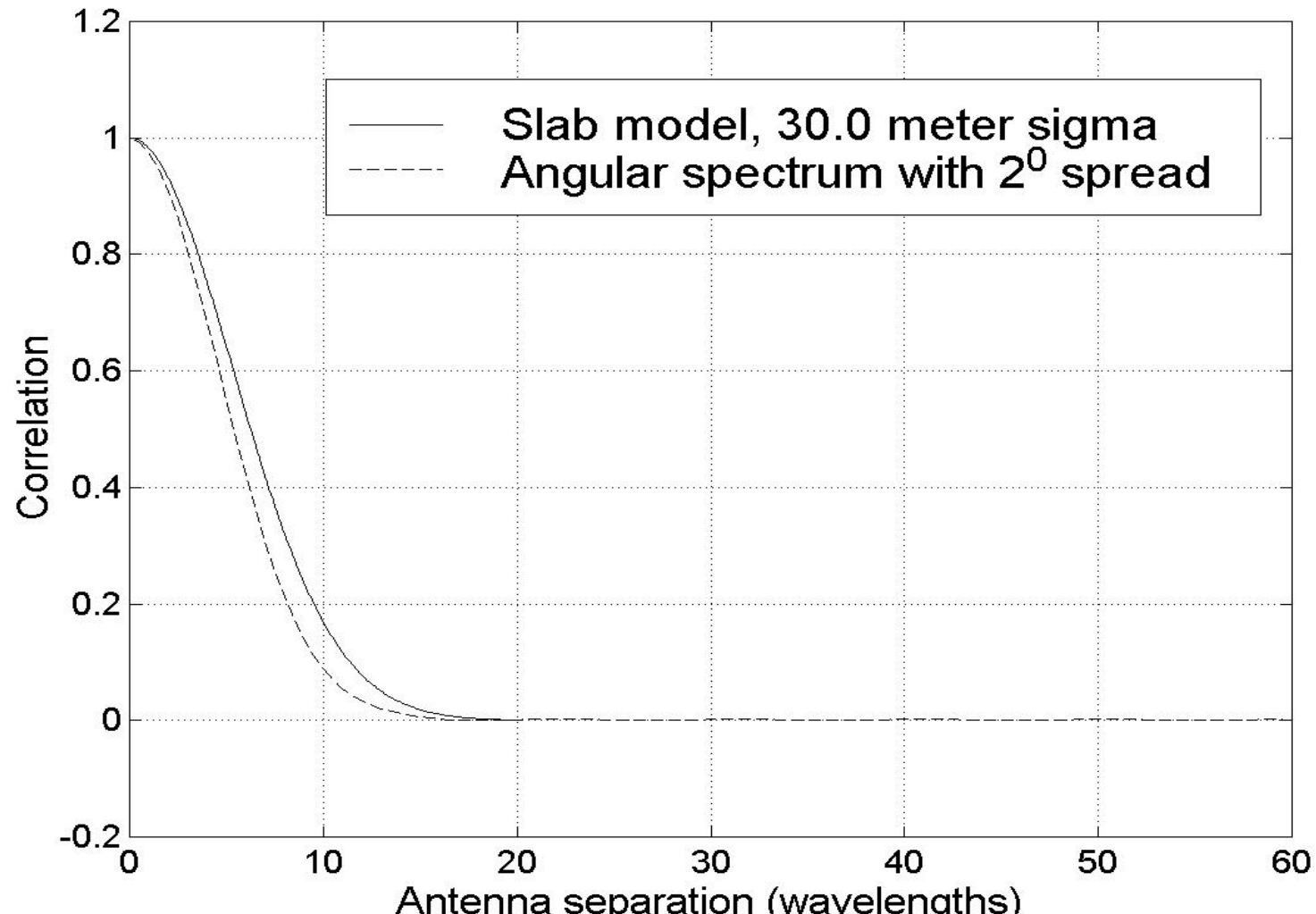

Summary for outdoors

- Using this correlation in the capacity formula:

$$C = \log_2 \left| \mathbf{I} + \frac{\rho}{n_T} \mathbf{H} \mathbf{H}^\dagger \right|, \quad \mathbf{H} = \sqrt{\Phi_R} \mathbf{H}_{iid}$$

- results in 80% of Rayleigh *iid* capacity for antennas separated horizontally by 4λ .

Propagation Modeling Conclusions

- **Decorrelation is not a guarantee of BLAST performance**
- **Existence of keyholes postulated and demonstrated in canonical situations.**
- **Statistical properties discussed and detection of keyholes proposed.**
- **Canonical outdoor propagation scenario is analyzed:**
 - **Keyhole found for vertically spaced antennas**
 - **Adequate decorrelation and BLAST performance for horizontally spaced antennas (4λ apart)**
- ***Nightmare scenario*: A vertical edge following a roof edge would leave only 2 degrees of freedom for 2 polarizations (conceivable, but unlikely)**

Experimental Evidence: Measuring BLAST capacities

Eight Easy Steps to BLAST capacity measurements

1. Send 16 unique RF tones (centered at 2.11 GHz), one per antenna, each separated by 2kHz.
2. Receive 16 I/Q tone pairs, store time series data to disk at 78,125 Samples/sec/channel.
upwards of 3 Gbytes per data run including static and mobile data.
3. Record LAT/LON position with Global Positioning System enhanced with inertial guidance.
4. Drive around recording 16 time series to disk.
5. Come home, post process data as 120 point FFTs.
1.5 milliseconds/H = 650 Hz channel update rate
measure transmitted tones as signal power
measure adjacent tones as noise power
calculate average measured SNR
6. Guarantee adequate measured SNR (guard against poorly recorded H matrix).
7. Assign system SNR (assume signal as power controlled, typically 10 or 20 dB).
8. Substitute into log det formula.

$$C = \log_2 \det [I + (\text{SNR} \cdot N/M) H H'] \quad [\text{bits/sec/Hertz}]$$

SNR = system SNR

H = normalized to unit variance, dimension $M \times N$

(measured with sufficiently high accuracy, referred to as measured SNR)

H' = matrix transpose

M = no. of transmitters

N = no. of receivers

Error in Measured Rician Channel Capacity

$N=M=16$

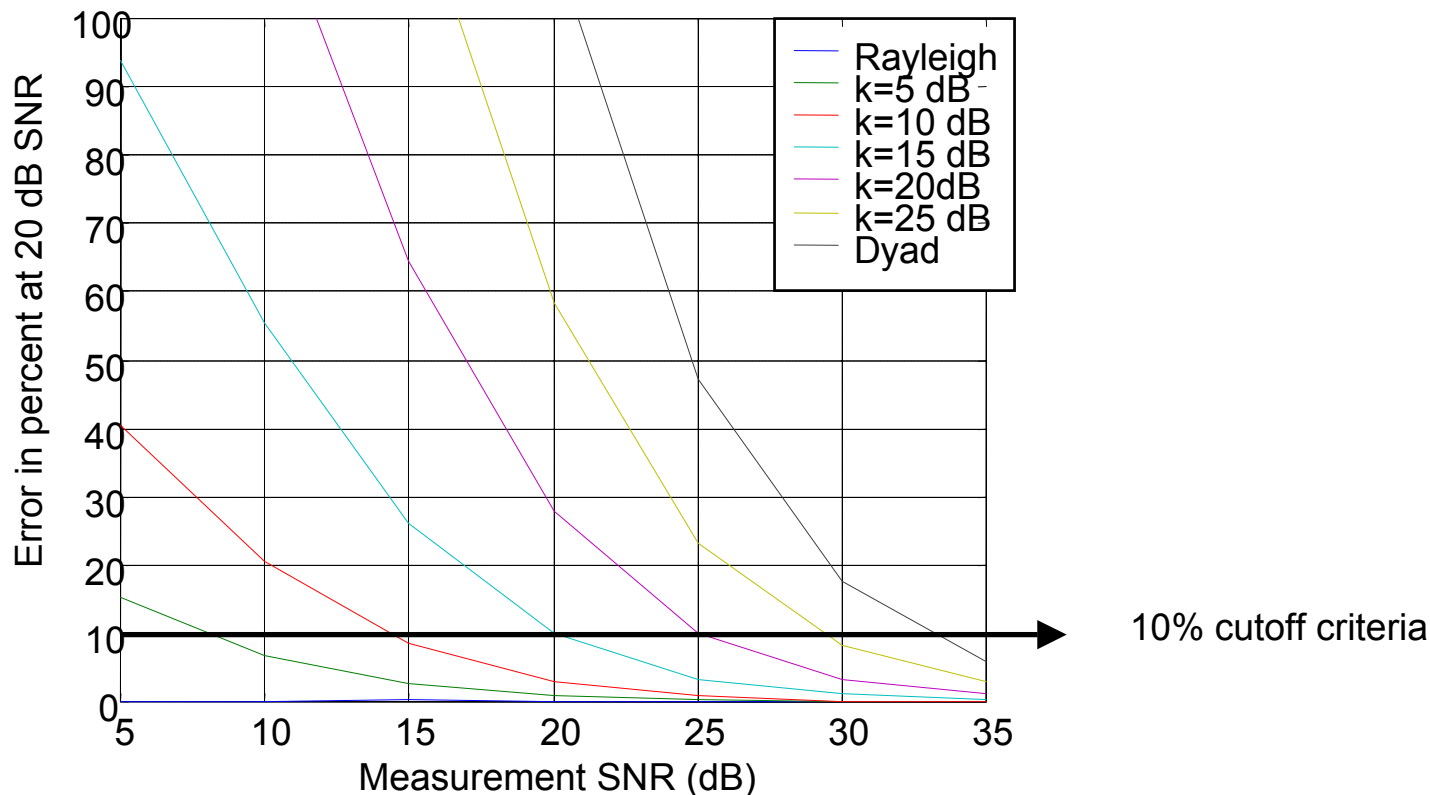

Estimated Capacity vs. Measurement SNR, Rician Channel, N=M=16

Rician K factor = specular power/scattered power

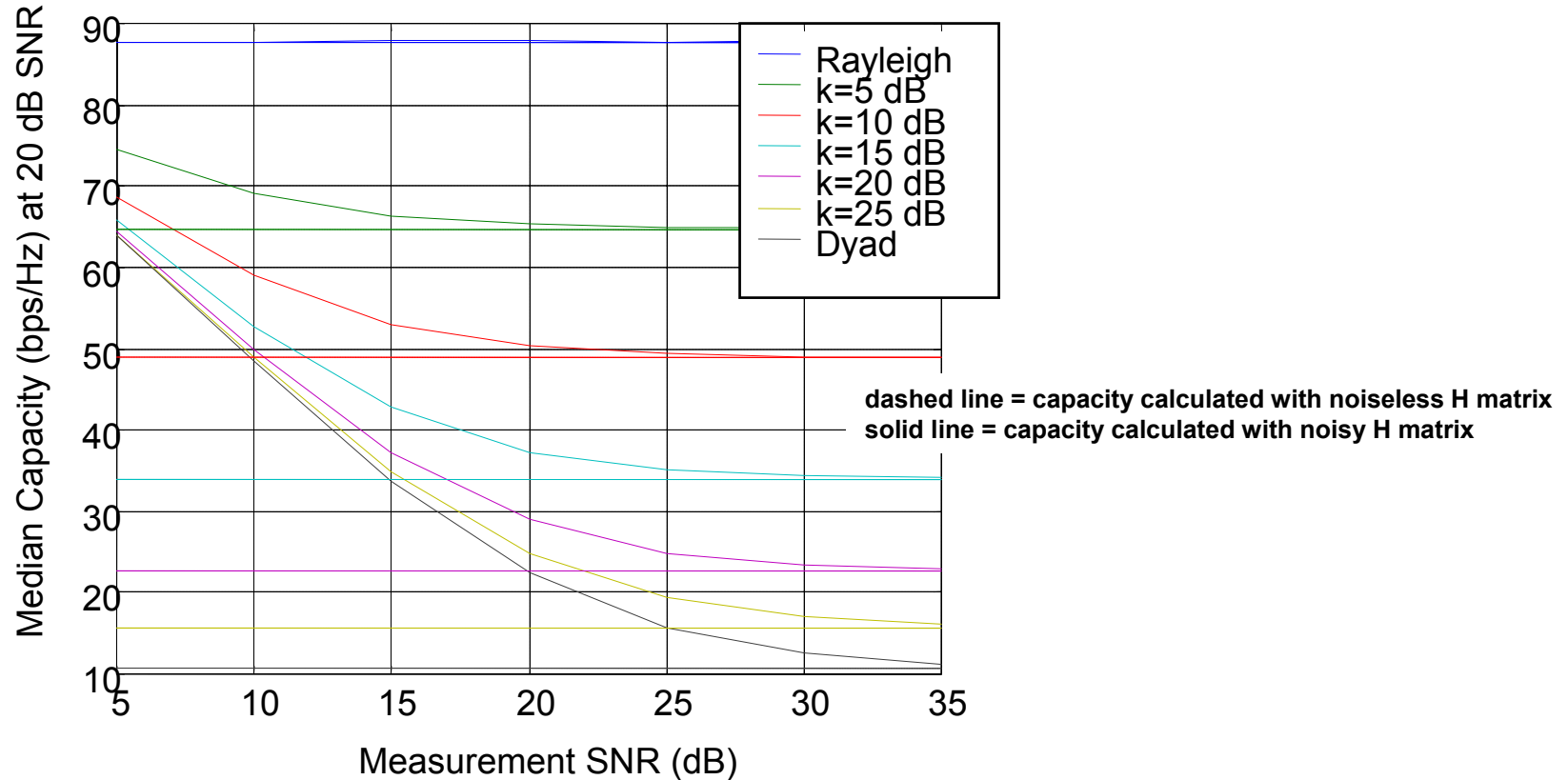

Calibration: Measured and Theoretical Capacity over ground plane

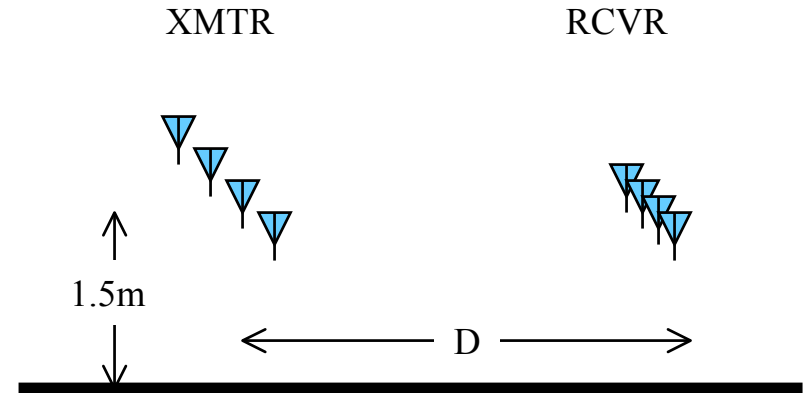
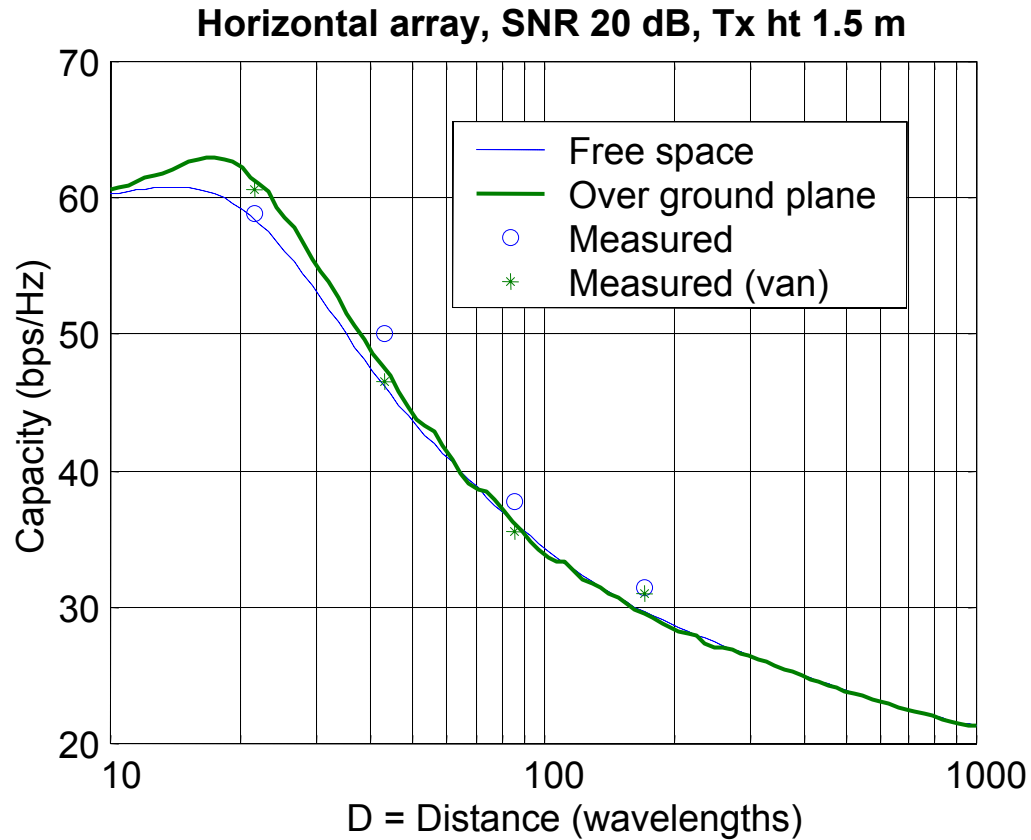

Experimental Evidence

- The BLAST prototype has **demonstrated unprecedented bandwidth efficiencies (30-40 bps/Hz)**. Over 1 Mbps within a 30-kHz channel that typically delivers about 50 Kbps.
- Without the parallel channels created by BLAST, it is **impossible** to even approach this type of bandwidth efficiencies.
- Excellent **agreement** between **theory and experiment** in indoor environments.
- To achieve 40 bps/Hz, a conventional single-antenna system would require a constellation with $2^{40} = 10^{12}$ points ...!
- Furthermore, a constellation with such density of points would require SNR levels in excess of 100 dB to operate at any reasonable error rate.

V-BLAST Prototype

- A 1.9-GHz, 30 KHz, V-BLAST prototype with 12 transmit and 16 receive antennas is operational at the Crawford Hill facilities.



Hardware prototype



V-BLAST Single Position Indoor Results

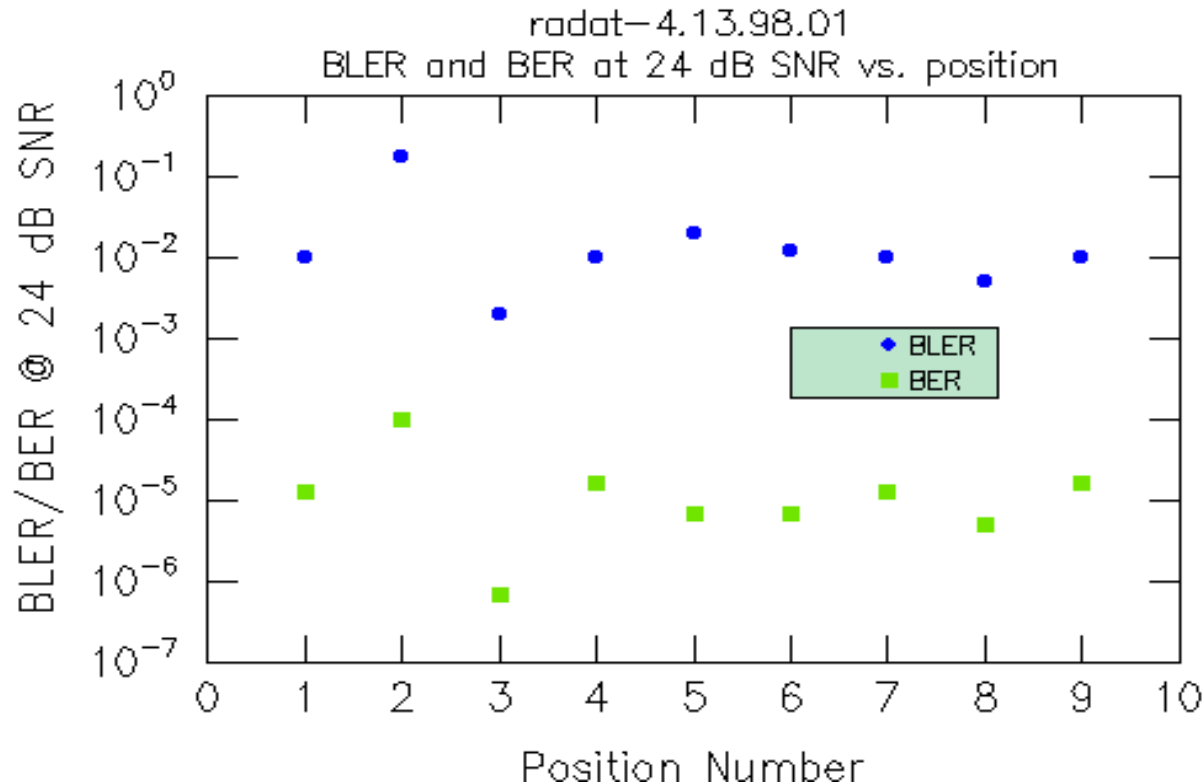

$M = 8$ (8 x 16QAM)

$N = 12$

$E_s = 26$ bps/Hz

$k = 100$ symbols

(20 training + 80 payload)

Raw data rate = 780 kbps

Payload rate = 624 kbps

BLER = 3200 bits

Measurement Setup

Goal:

- Evaluate BLAST capacity in suburban environments.
- Characterization of MIMO Channel.

Measurement Setup:

- Base station:
 - horizontal array of 5 antennas
 - 15° HPBW, 13 dB gain, 0.52 m spacing
 - h_t : 34.7 m on top of Crawford Hill
 - 5 discrete frequency tones
 - f_c : 2.44 GHz + [8:12] KHz
 - P_t : 30 dBm/Ant
- Remote:
 - horizontal array of 4 antennas
 - vertical array of 4 antennas
 - 26° HPBW, 15 dB gain, 1.1 m spacing
 - h_r : 10 m and 5 m.
 - Speed: 10 ms per H, 30 s per 300 H.



BLAST Outdoor Measurements



Narrow Band
5 Transmit and
7 receive elements
35 m base
10 m remote
2 GHz

35 m Base Station Height
5 transmit elements

10 m Remote Station Height
7 receive elements

20 dBm Total Transmitter Power
30 kHz Bandwidth
10 dB Noise Figure
Path Loss Fluctuations included
over an 11 km radius cell size

Cumulative Distribution of the Capacity for Sixteen Locations, 10m Remote Height, SNR = 7 dB

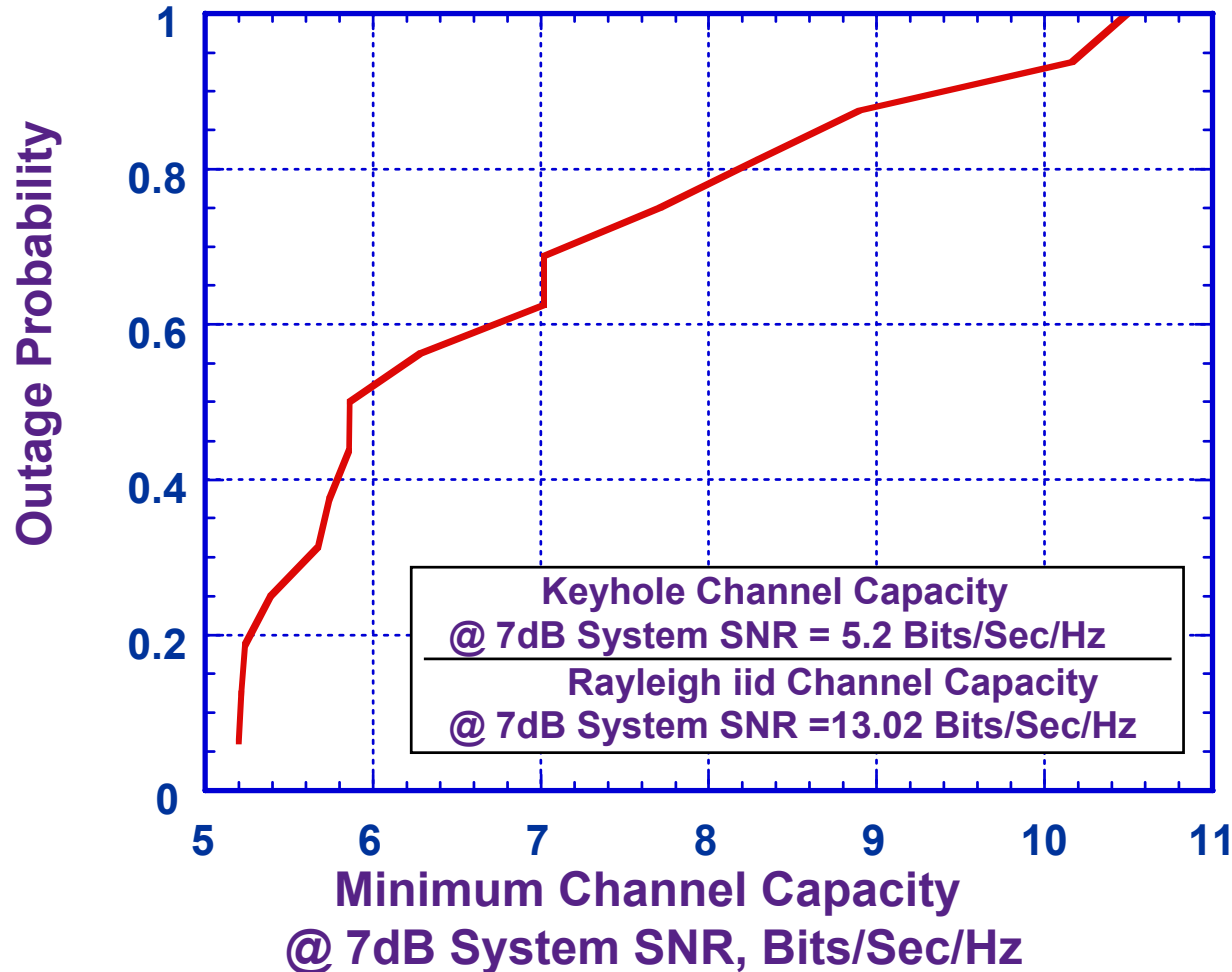

35 m Base Station Height
5 transmit elements

10 m Remote Station Height
7 receive elements

20 dBm Total Transmitter Power
30 kHz Bandwidth
10 dB Noise Figure
Path Loss Fluctuations included
over an 11 km radius cell size

Cumulative Distribution of the Capacity for Sixteen Locations, 10m Remote Height, SNR = 17 dB

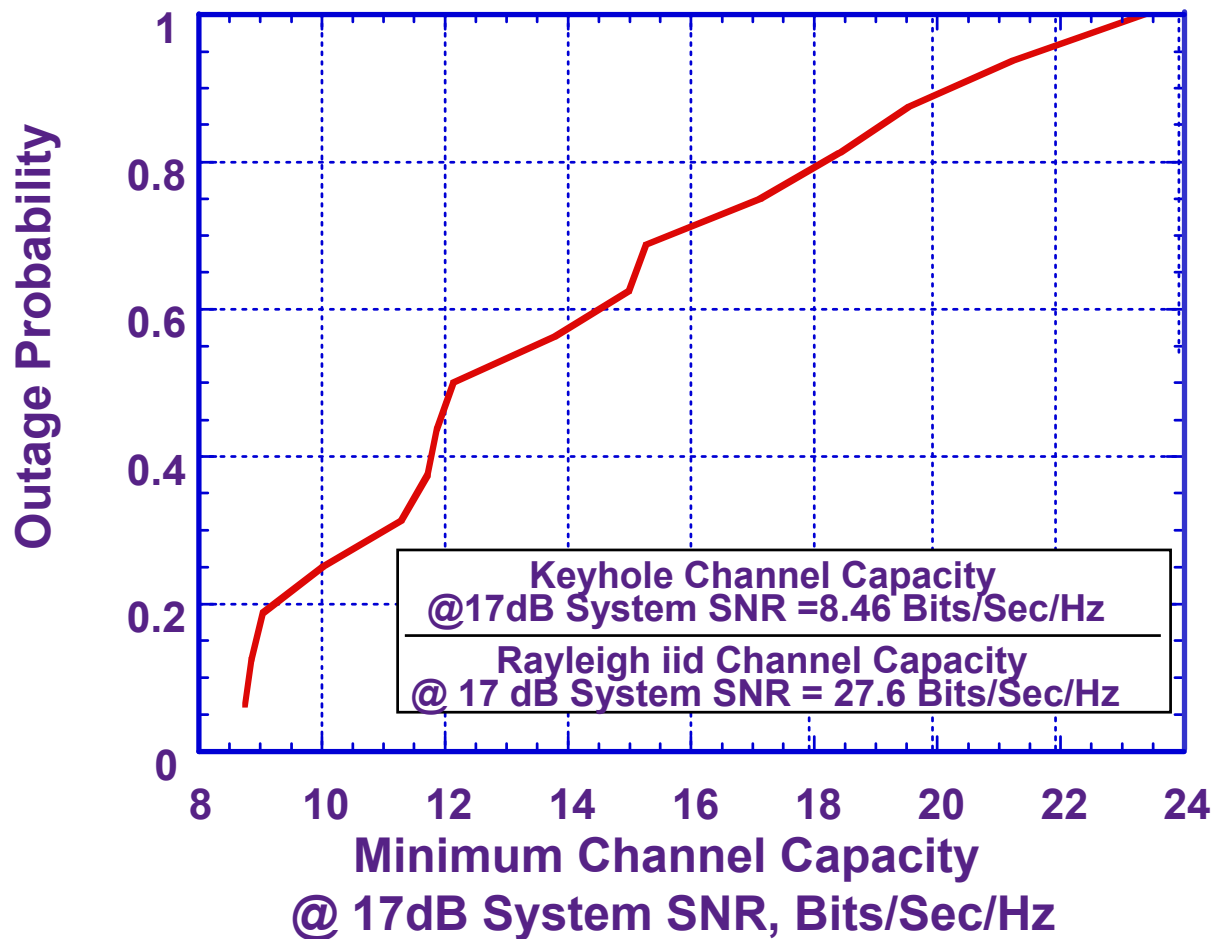

For All Curves:

35 m Base Station Height
5 transmit elements

10 m Remote Station Height
7 receive elements

20 dBm Total Transmitter Power
30 kHz Bandwidth
10 dB Noise Figure
Path Loss Fluctuations included
over an 11 km radius cell size

BLAST Capacity Probability in Suburban Environment, 5x7

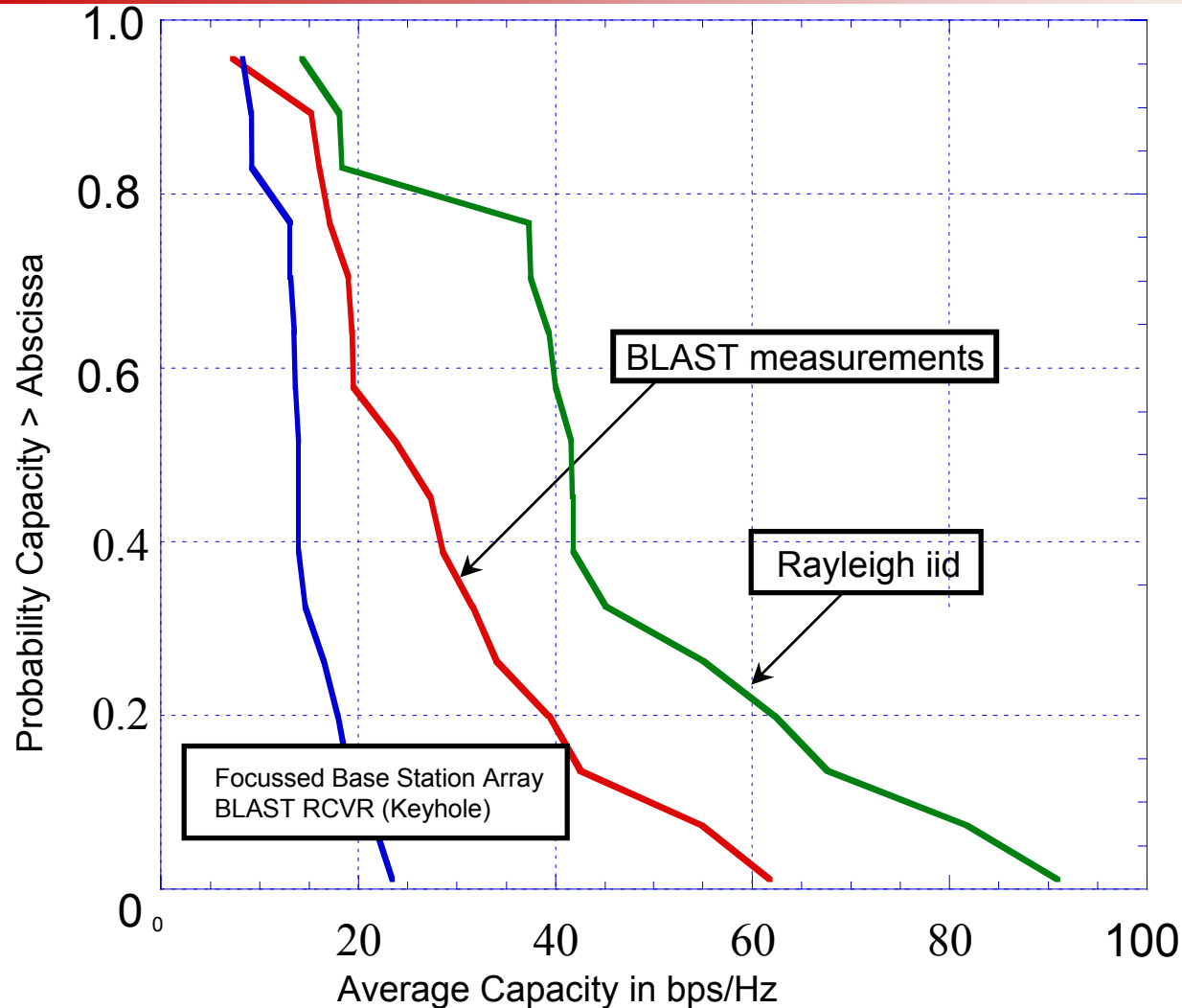

Suburban results

For All Curves:

35 m Base Station Height
5 transmit elements

10 m Remote Station Height
7 receive elements

20 dBm Total Transmitter Power

30 kHz Bandwidth
10 dB Noise Figure

Path Loss Fluctuations included
over an 11 km radius cell size

Conclusion:
Directional Suburban BLAST
is half-way to Rayleigh iid.

Average Measured Capacity Vs. System SNR

Sixteen Locations, 10m Remote Height

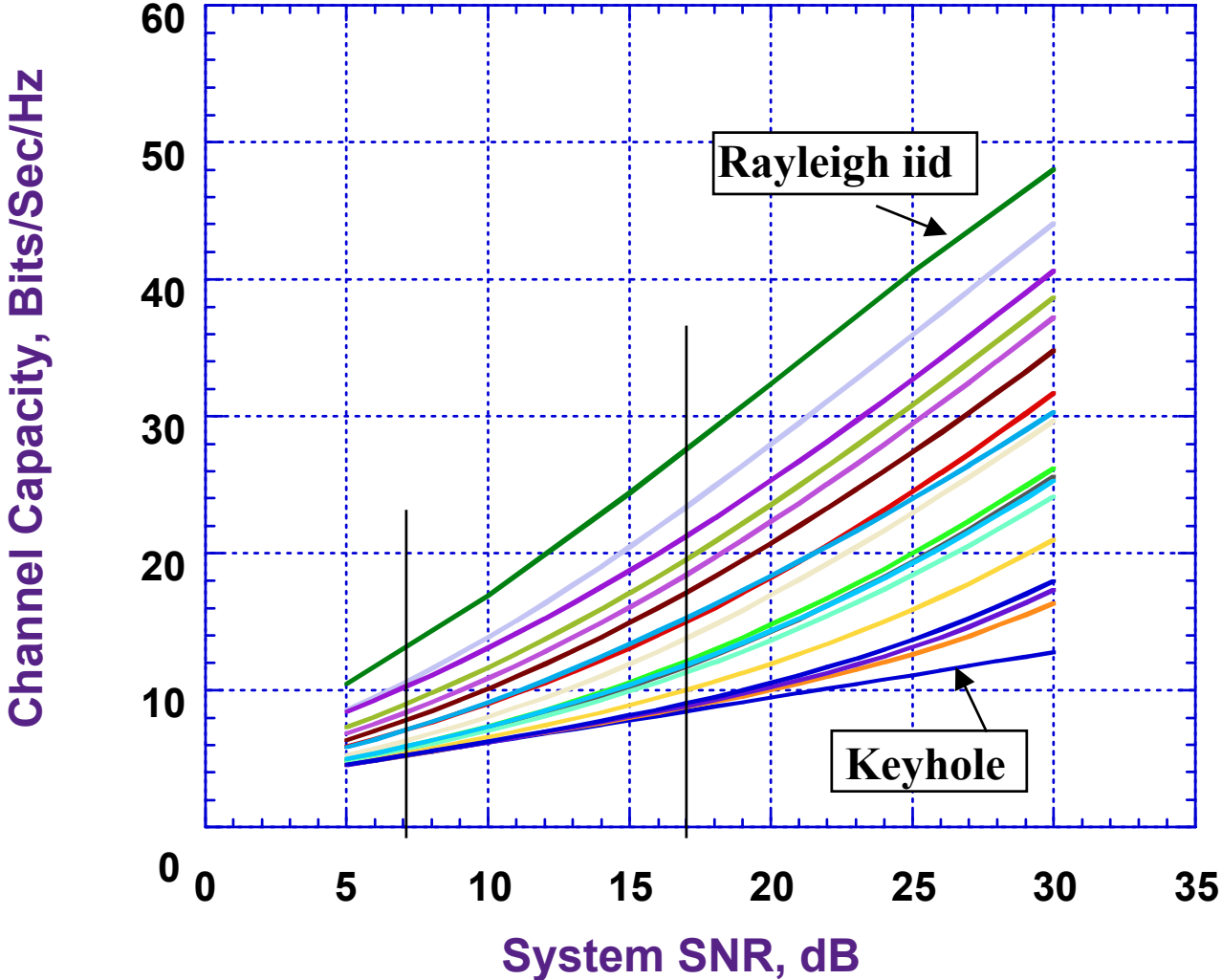

For All Curves:

- 35 m Base Station Height
- 5 transmit elements
- 10 m Remote Station Height
- 7 receive elements
- 20 dBm Total Transmitter Power
- 30 kHz Bandwidth
- 10 dB Noise Figure
- Path Loss Fluctuations included over an 11 km radius cell size

Effects of Remote Antenna Height

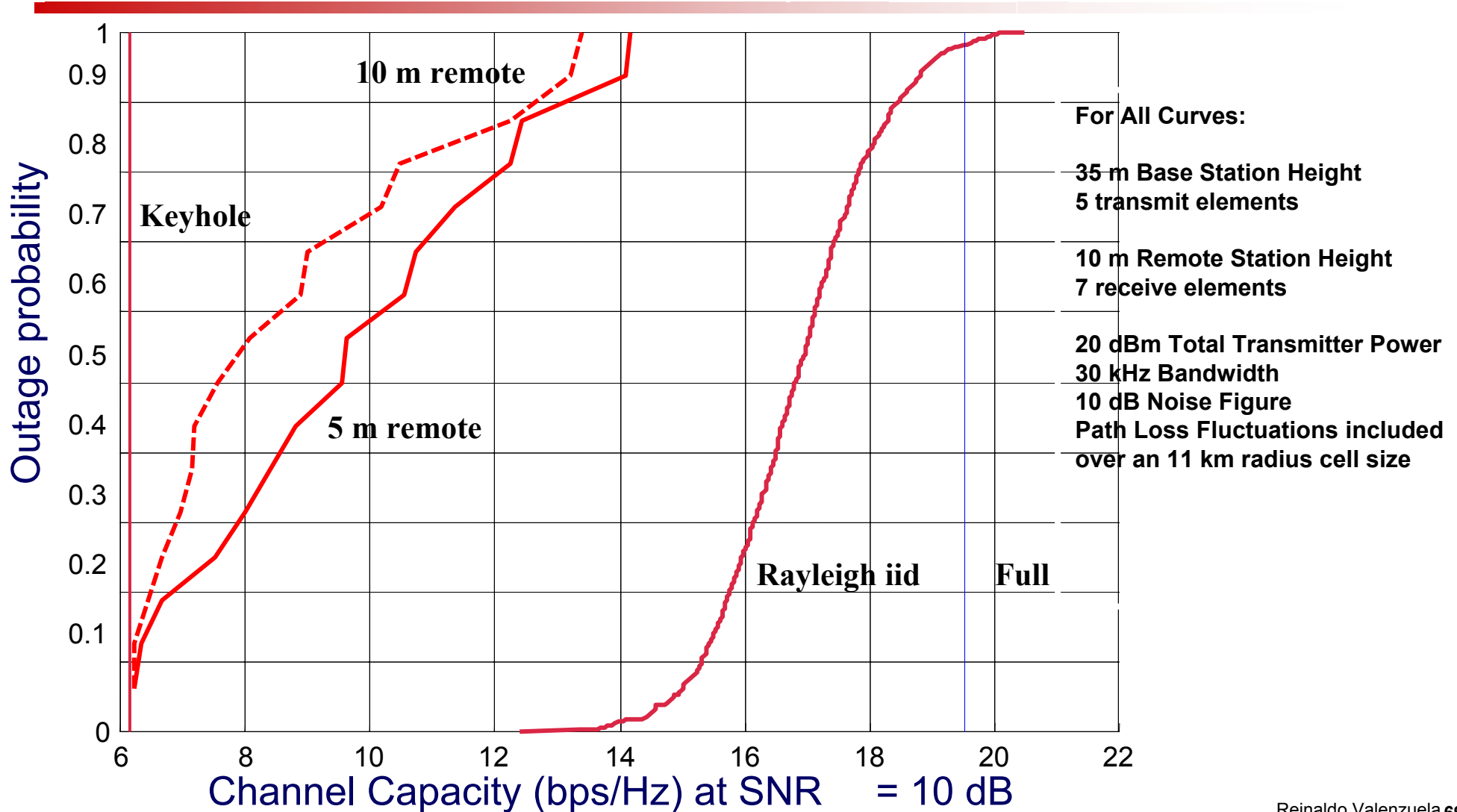

Conclusion (suburban)

- Measured capacities range from key-hole to Rayleigh iid
- **Median** capacity is about **55%** of the capacity **of Rayleigh iid** at **10 dB** system SNR
- Capacity is higher at lower remote antenna height due to additional scattering
- Both vertical and horizontal arrays contribute to the overall capacity of the channel

Urban Locations: Experiment goals

- **Measure capacity supported by real channels in urban and suburban environments**
- **Determine the impact of antenna spacing, polarization, antenna height, range, environment, etc. on capacity.**
- **Develop channel models to allow performance assessment of proposed systems and algorithms**

BLAST Capacity in Urban: (Manhattan) Environment, 16x16

• Goal:

- Evaluate BLAST capacity in dense urban environments using plausible antennas at transmitter and receiver.
- Characterize MTMR Channel for stationary and low mobility subscribers

• Measurement Setup:

– Base station:

- horizontal 2x8 array of polarized antennas
- 60° HPBW, 4.16 dBi gain, 2 and 4 lambda spacing
- h_t : 100 m.
- 16 discrete frequency tones
- f_c : 2.110 GHz + [4:32] KHz
- P_t : 23 dBm/Ant

– Remote: van mounted

- 4x4 array of alternating polarizations with laptop profile
- 60° HPBW, 4.16 dBi gain, 1/2 lambda spacing
- h_r : 1.5 m.
- 1.5 ms per H or 650 H matrices/second



VSNR: Transmitter Block Diagram

Transmit 16 RF (2.1 GHz) tones separated by 2 kHz

2X8 Transmitting Antenna Array with two polarizations

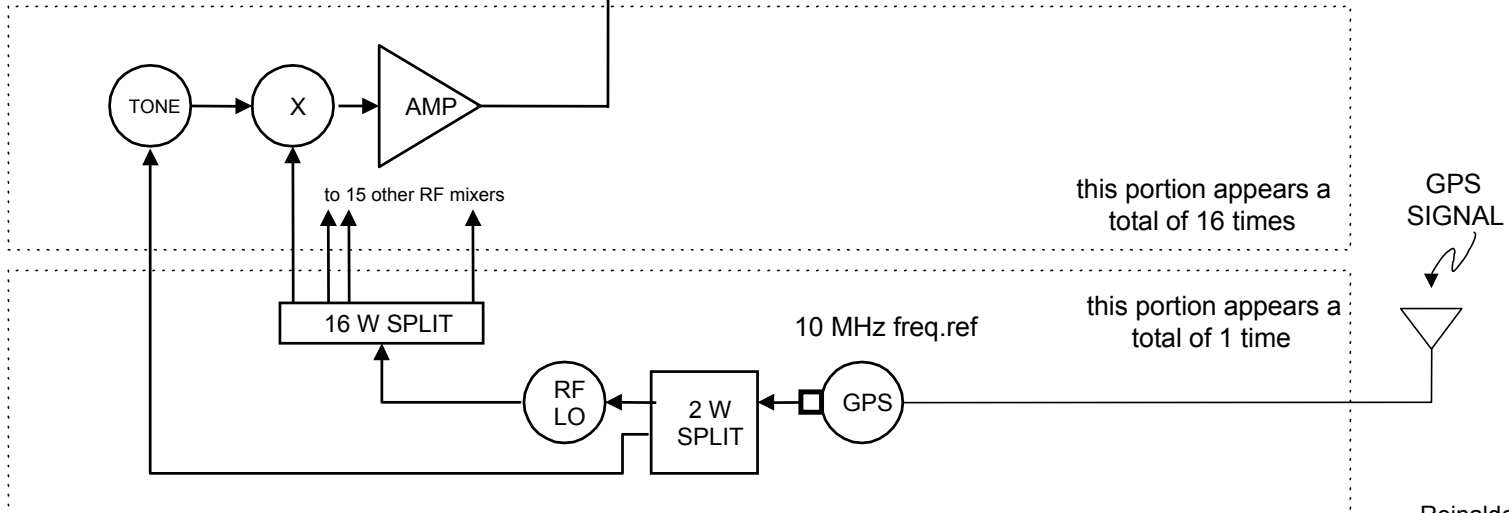
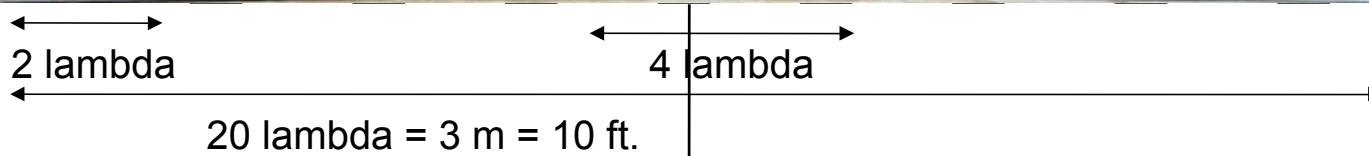
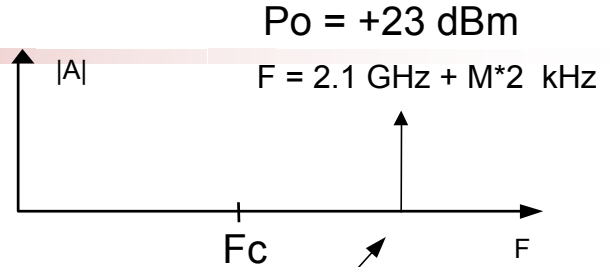

LEGEND
 → SMA coax cable or connector

Multiple Antenna Terminals...

Many elements can be integrated on a laptop or palm device



VSNR: Receiver Block Diagram

sample 16 radios at 650 Hz
channel update rate

$1/2 \lambda$

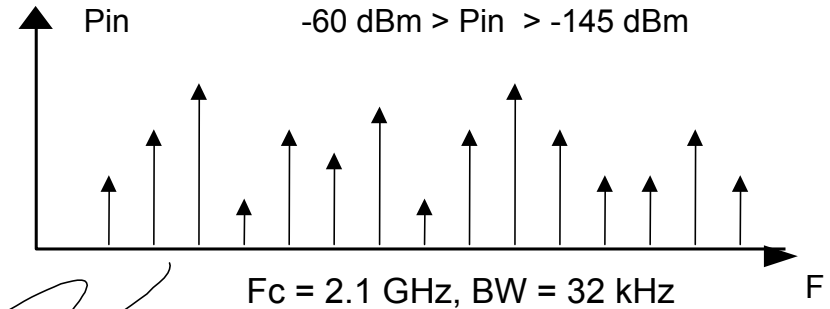
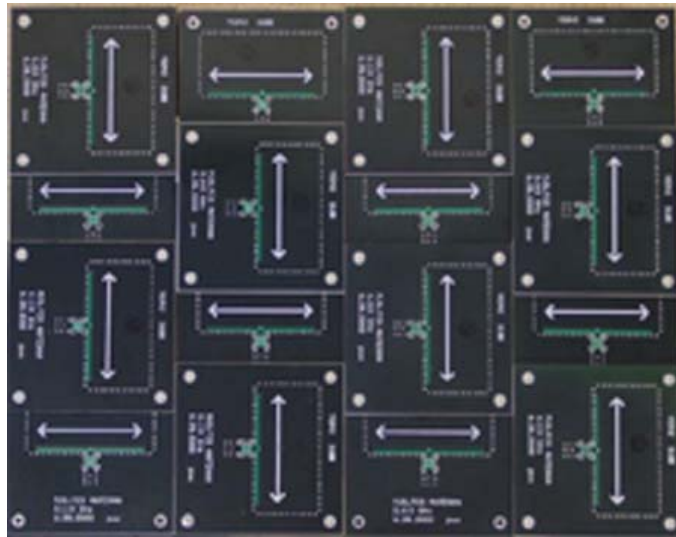

I/Q stream to disk

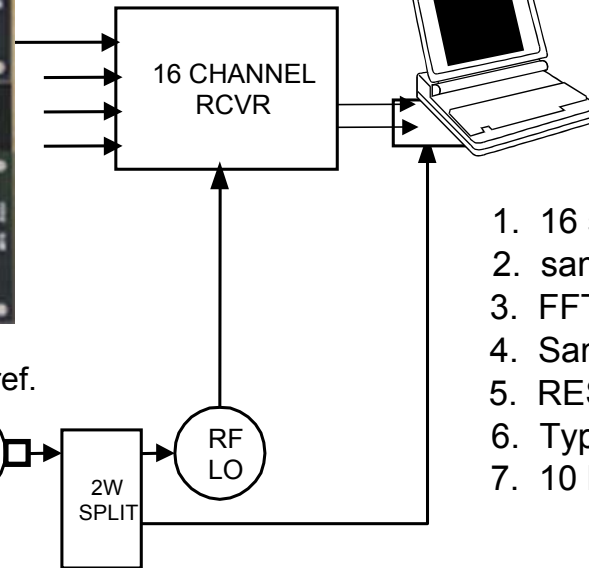

1. 16 simultaneous I/Q pairs
2. sample rate = 78,125 S/s/ch
3. FFT size = 120 points
4. Sample time = 1.5 ms
5. RES BW = 650 Hz
6. Typical file size = 2-3 GB
7. 10 MHz GPS freq. ref.

Capacity & SNR for Single Drive Run

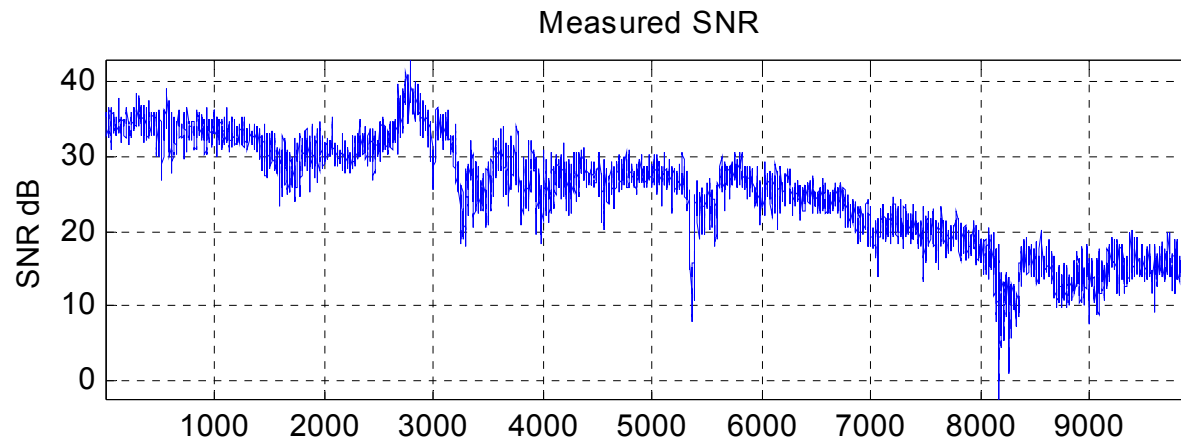
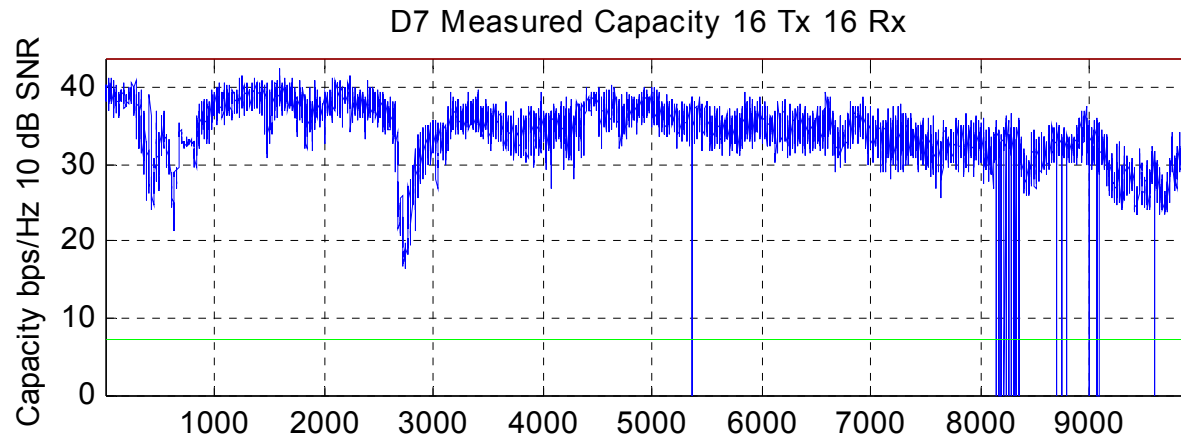

16 Tx 16 Rx
10 dB System SNR
Max 43 bps/Hz (Rayleigh IID)
Min 7 bps/Hz (Dyad)

Measured Manhattan Capacity & SNR for a Single Drive Run, D7

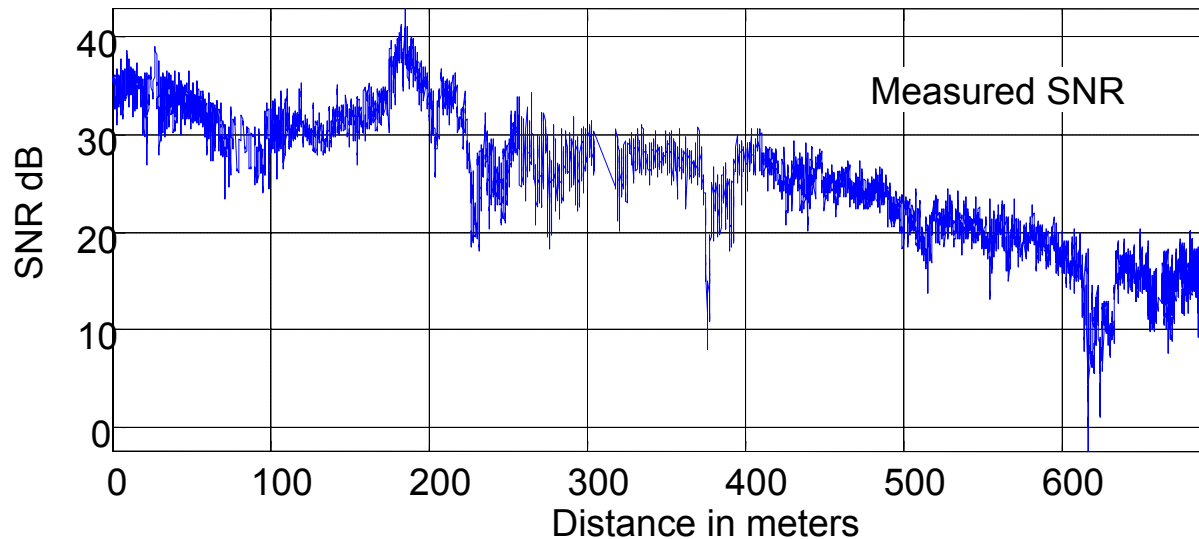
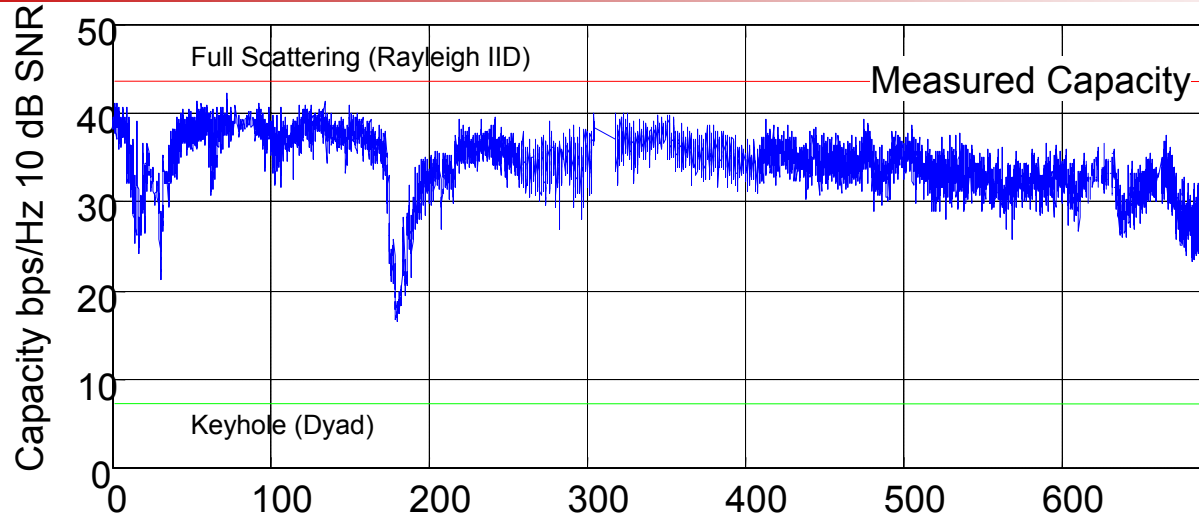

- 16 Tx 16 Rx
- 10 dB System SNR
- Max 43 bps/Hz (Rayleigh IID)
- Min 7 bps/Hz (Dyad)

Drive Route & Capacity

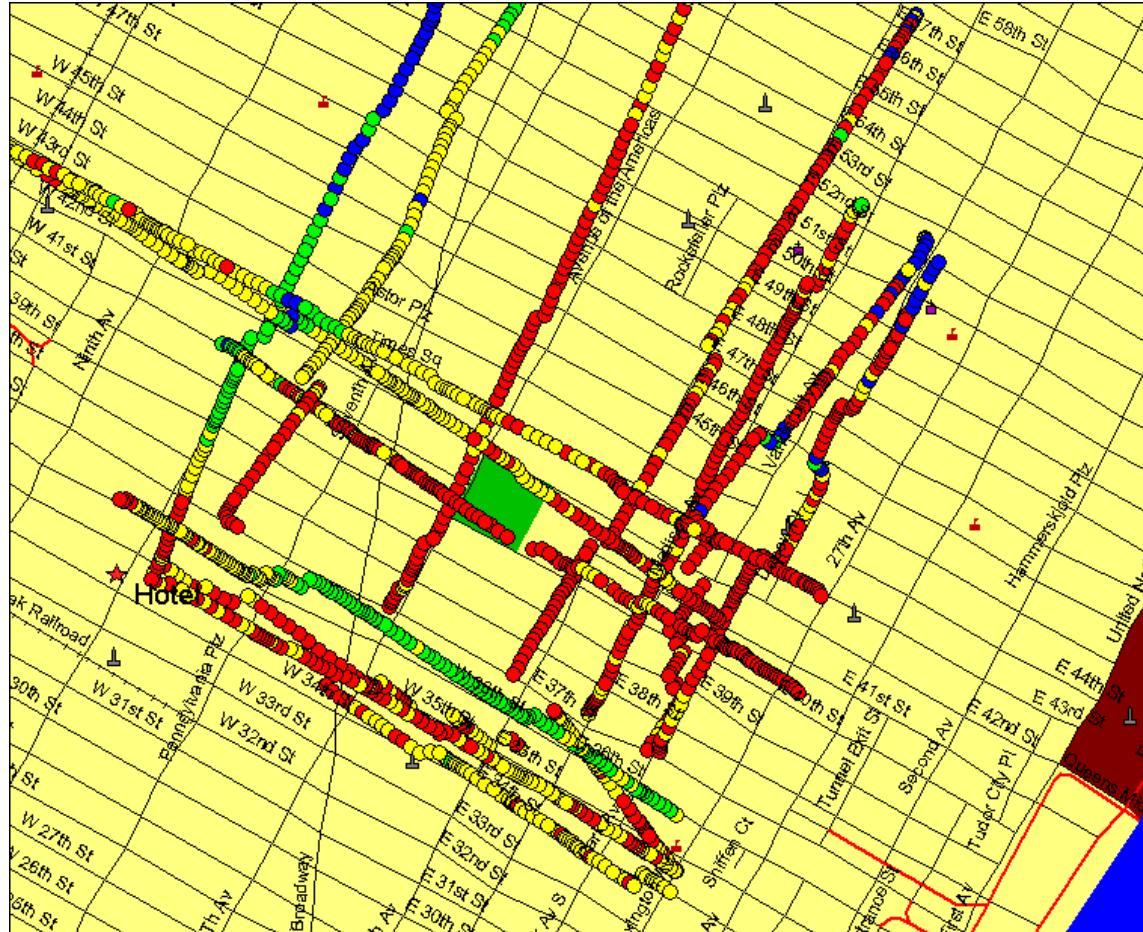

RED Very High 70 to 88 bps/Hz

YELLOW High 50 to 70 bps/Hz

GREEN Med. 30 to 50 bps/Hz

BLUE Low. 10 to 30 bps/Hz

16Tx 16 Rx

20 dB SNR

1 Mile Range

Midtown Manhattan Drive Runs and Color-Coded Capacities

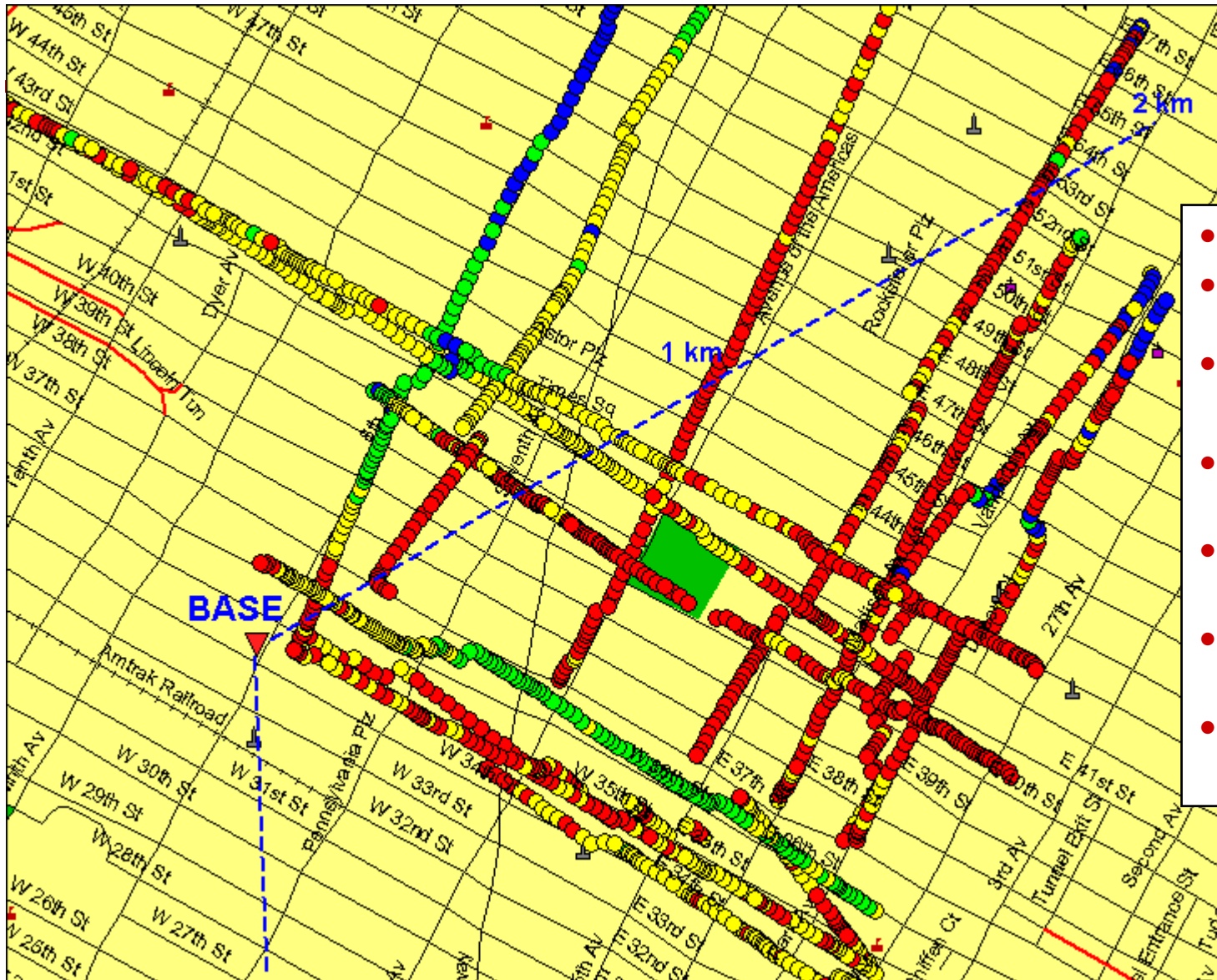

- 16Tx by 16 Rx
- 10 dB System SNR
>10 dB Measured SNR
- 2 km Range
- **RED** Very High
35 to 44 bps/Hz
- **YELLOW** High
25 to 35 bps/Hz
- **GREEN** Med.
15 to 25 bps/Hz
- **BLUE** Low.
5 to 15 bps/Hz

Capacity at Constant Tx Power, $N_t = N_r = 4$

System SNR = Measured SNR

Meas. SNR from 10 to 44 dB

For sys SNR from 5 to 22 dB,
just divide scale by 2.

Antenna Arrays:

Base height 100 m

Terminal height 1.5 m

H or V Polarized

1/2 wavelength spacing terminal

20 wavelength spacing at base

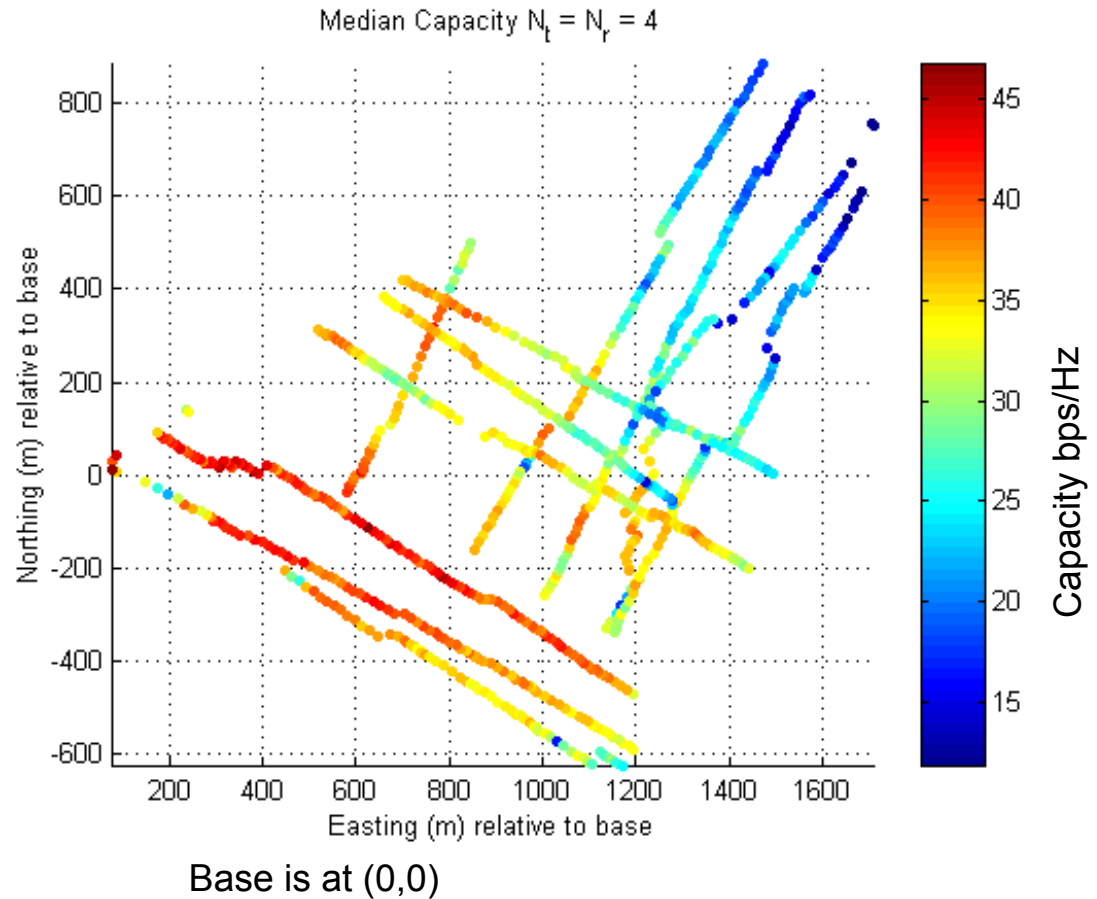

Capacity at Constant Tx Power, $N_t = N_r = 16$

System SNR = Measured SNR

Meas. SNR from 10 to 44 dB

For sys. SNR from 5 to 22 dB,
just divide scale by 2.

Antenna Arrays:

Base height 100 m

Terminal height 1.5 m

H or V Polarized

1/2 wavelength spacing terminal

20 wavelength total base size

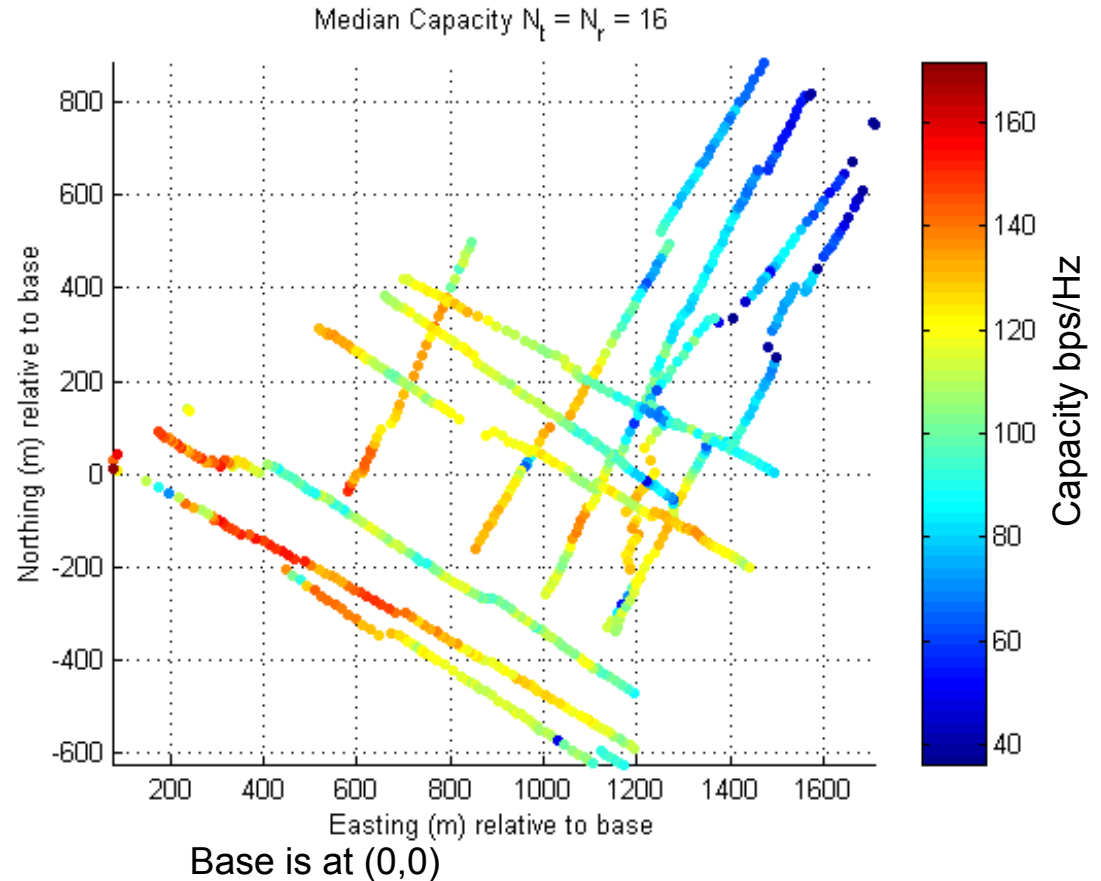

Measured Channel for BLAST 4Tx 4Rx

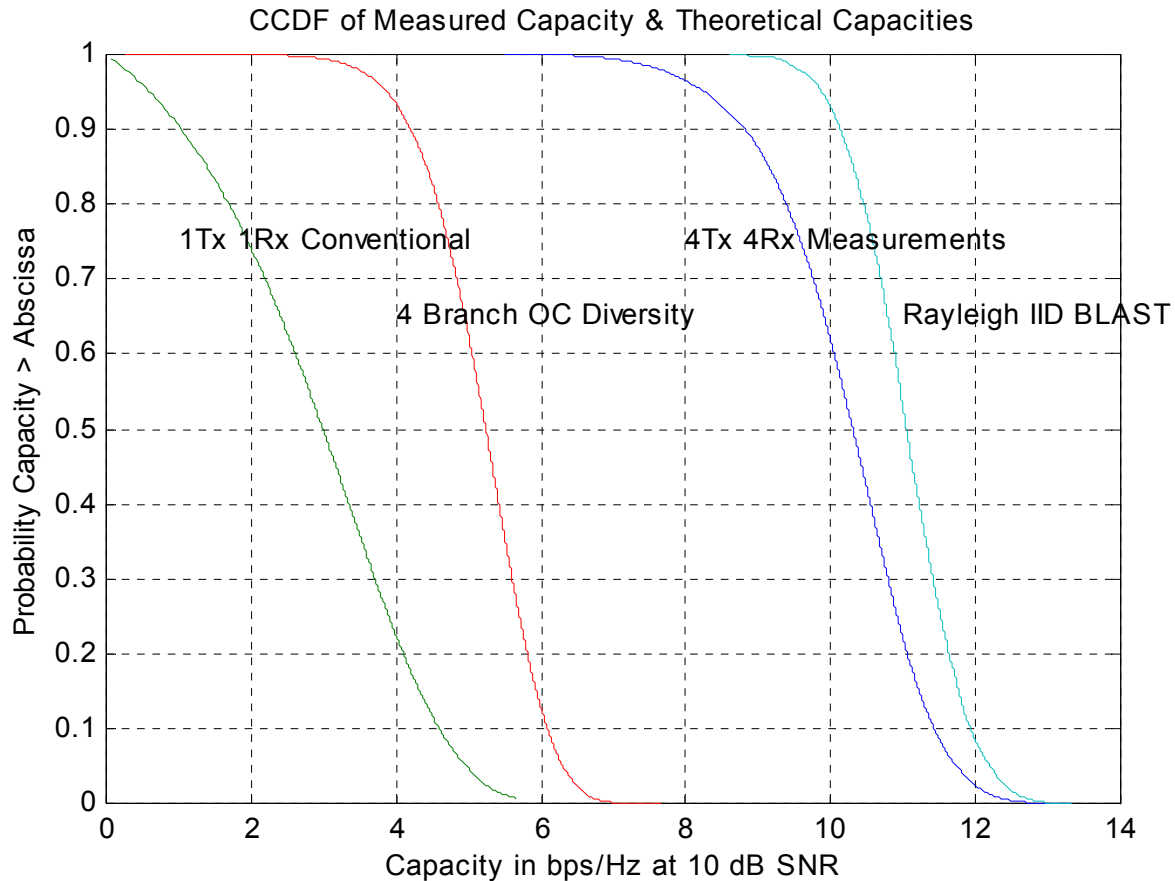

CDF is of entire dataset

Measured Capacity is 90% of Rayleigh IID

Measured and Theoretical Capacities: all Manhattan Data

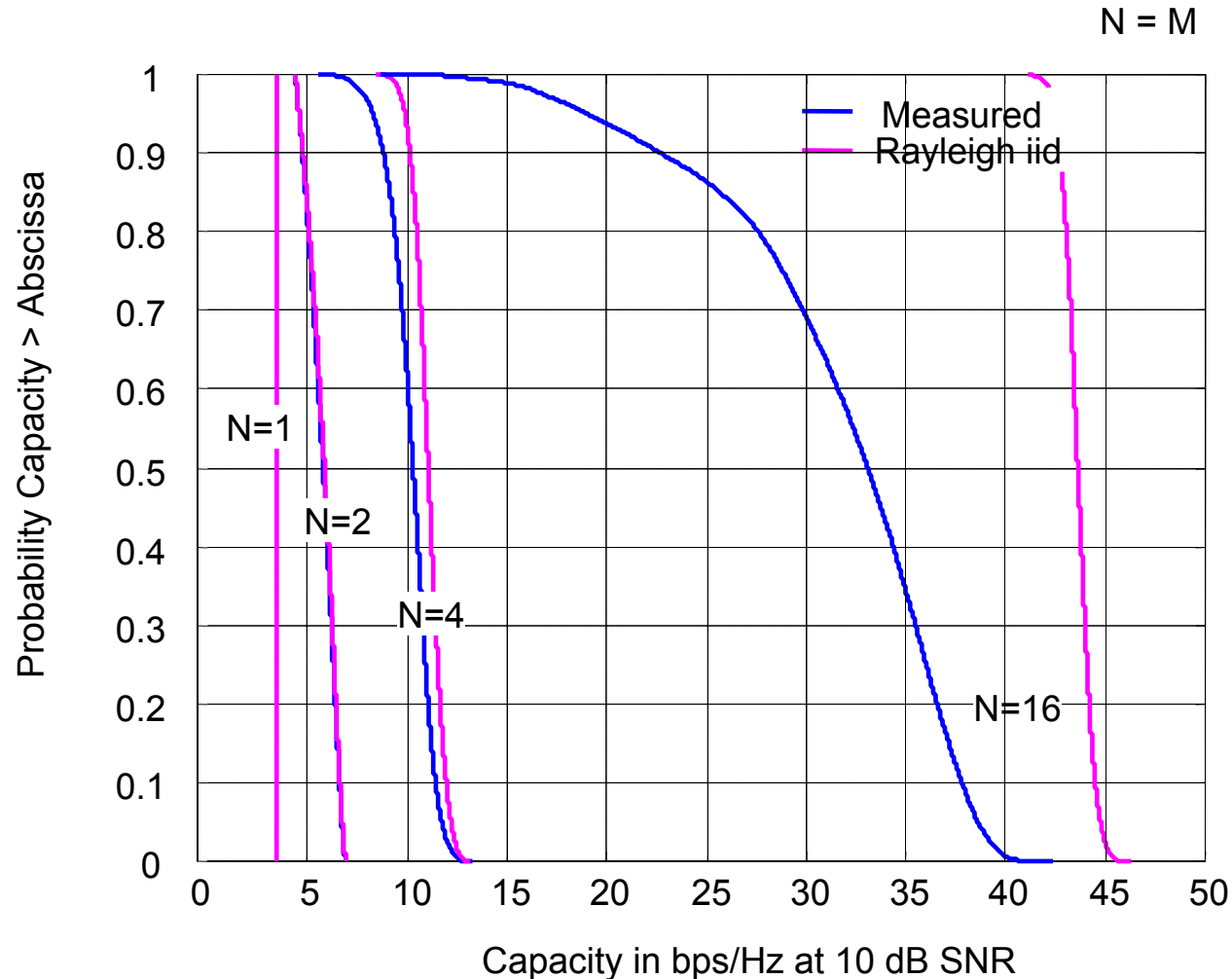

Capacity for 16Tx 16Rx

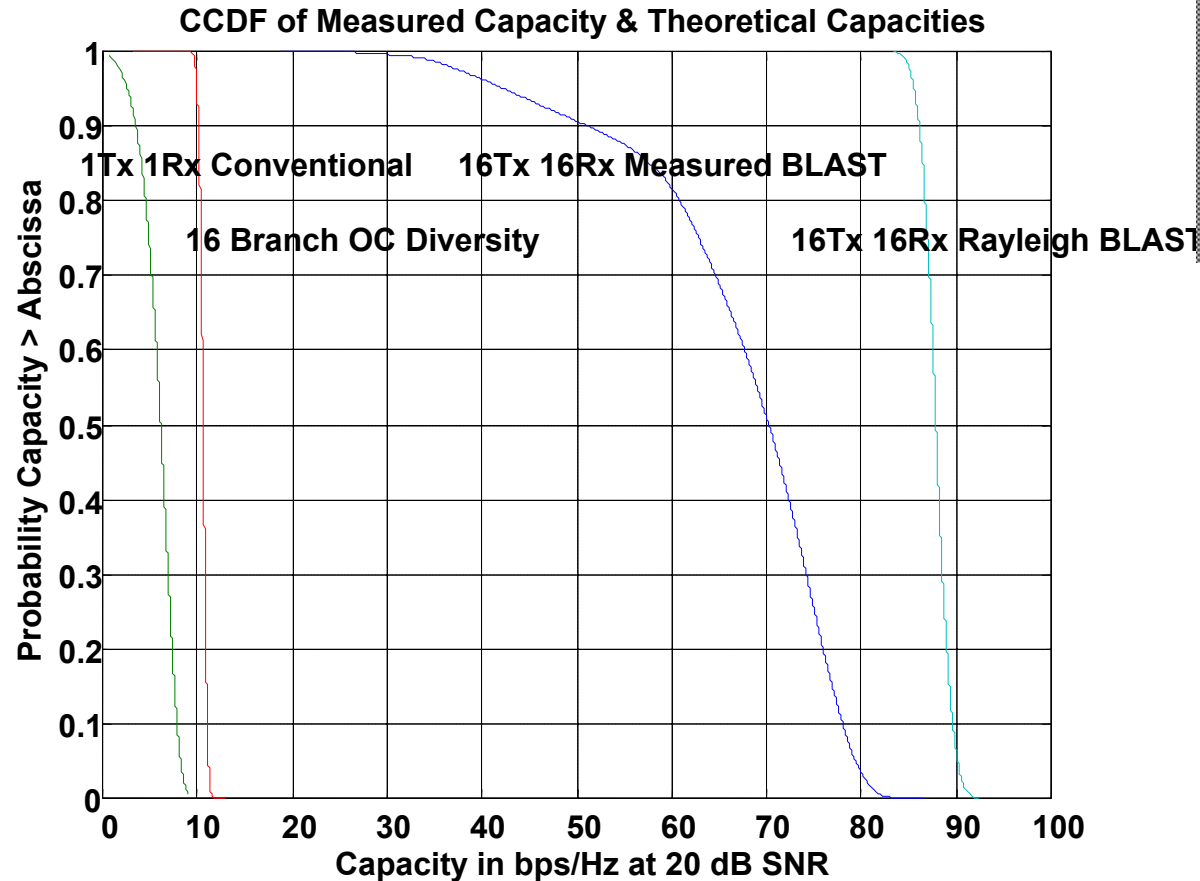

CDF is of entire dataset

Measured Capacity is 80% of Rayleigh IID

Theory: Correlated Gaussian channels

- **Separable correlation among transmit and receive elements:**

$$C = \log_2 \left| \mathbf{I} + \frac{\rho}{n_T} \Phi_R \mathbf{H} \Phi_T \mathbf{H}^* \right| \quad (\text{bps/Hz})$$

- **H has complex Gaussian *iid* entries**
- **ρ is average SNR**
- **Φ_R is the covariance matrix of the receive elements**
- **Φ_T is the covariance matrix of the transmit elements**
- **Hypothesis allows generation of H matrices based on local covariance or angular spectra**

Theory: Correlation vs. Antenna Separation

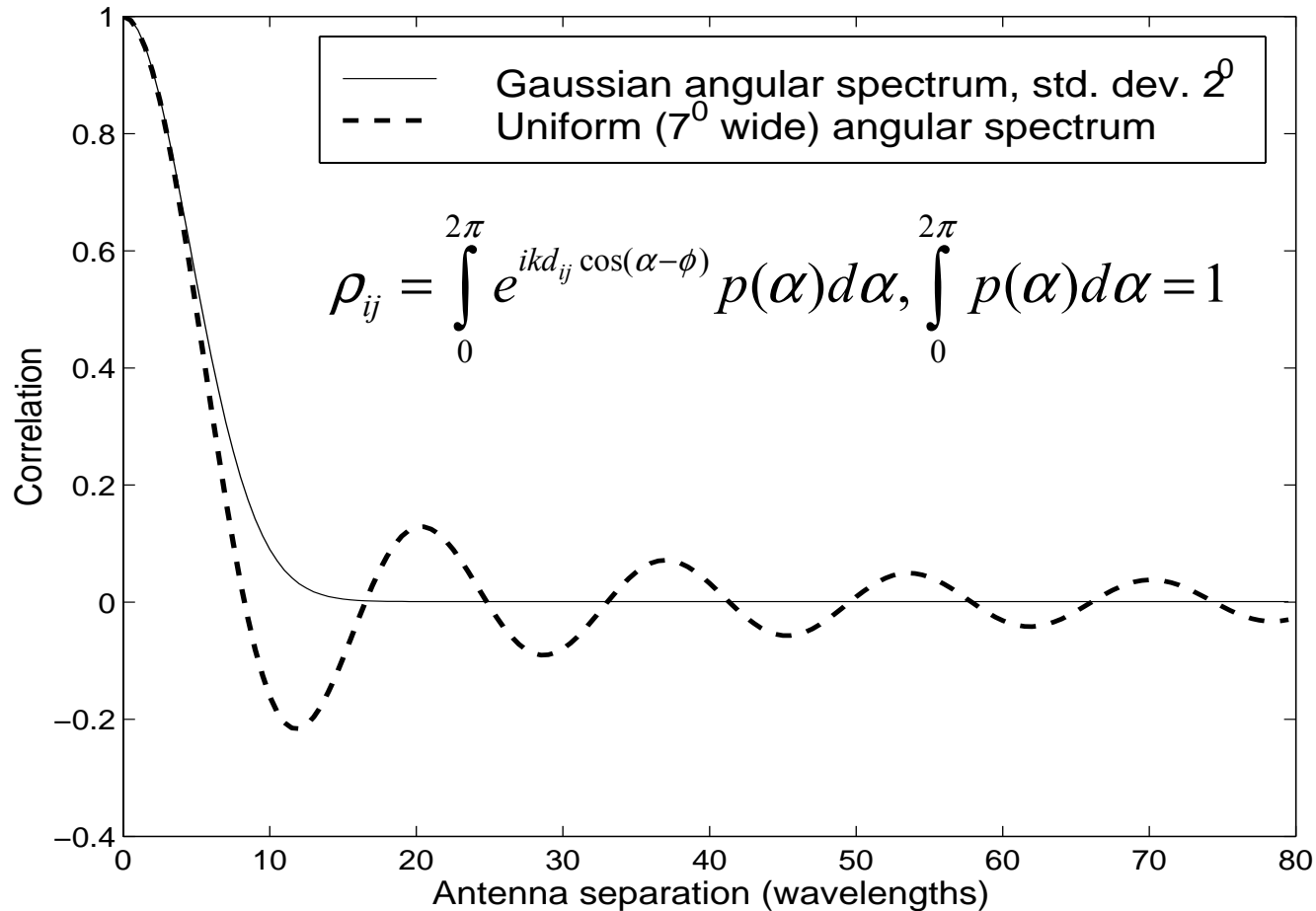

XMTR

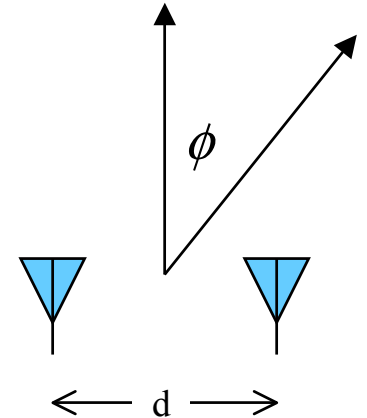

Theory: 90% Capacity bound vs. Antenna Separation

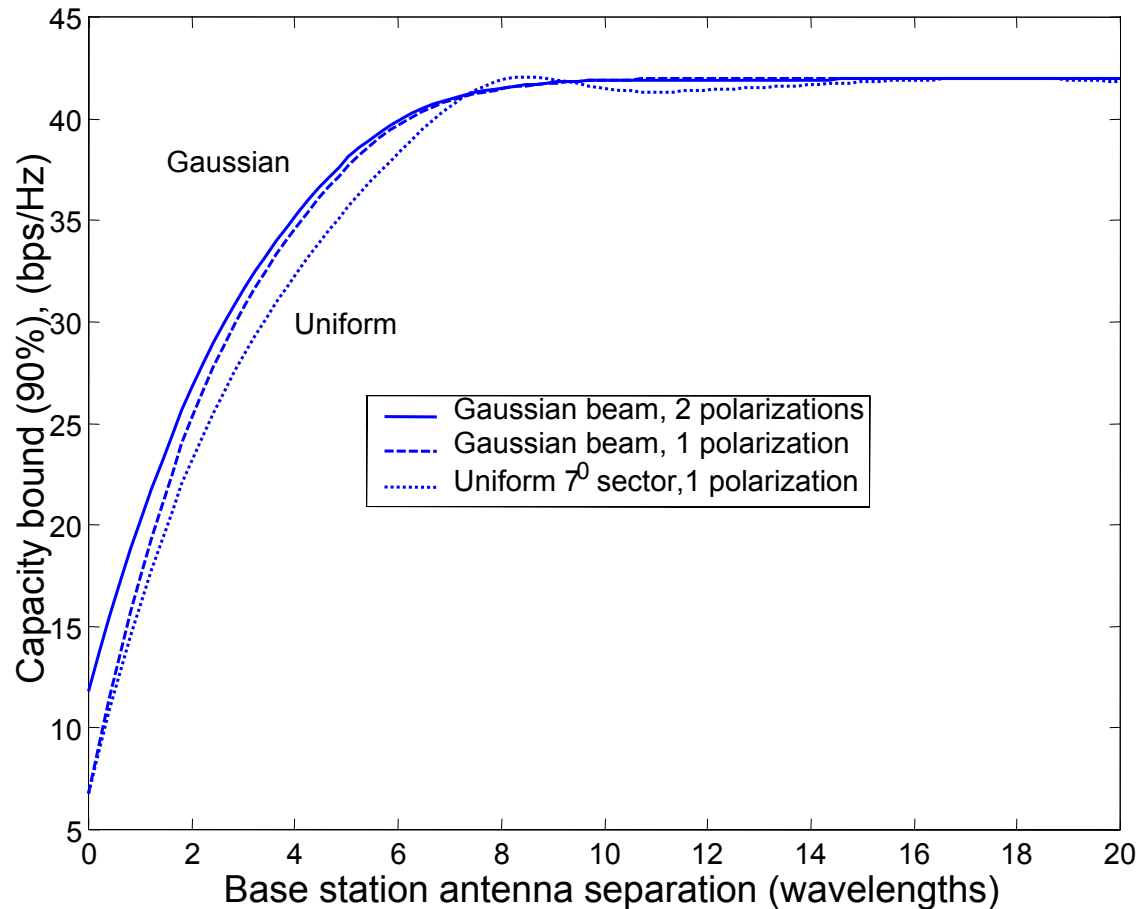

16 Transmitters,
2 deg rms angular spread at base station

16 receivers,
uncorrelated remote antennas

SNR 10 dB

XMTR

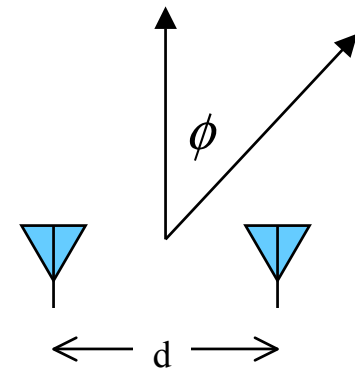

Theory: Capacity vs. antenna coupling, 16x16, 100 Scatterers/Ring, 10 dB System SNR

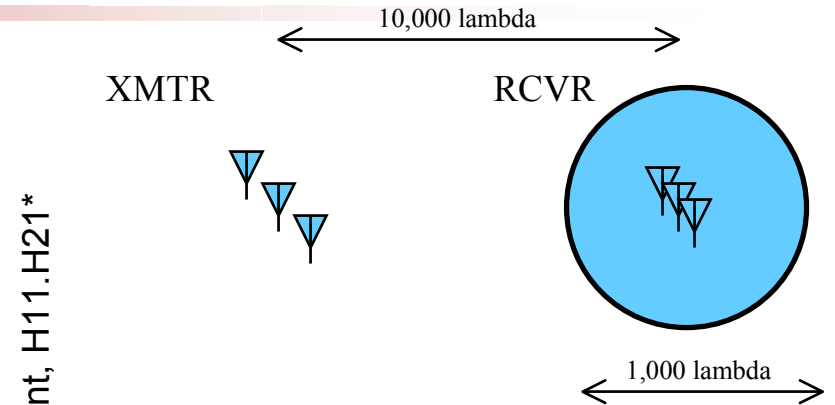
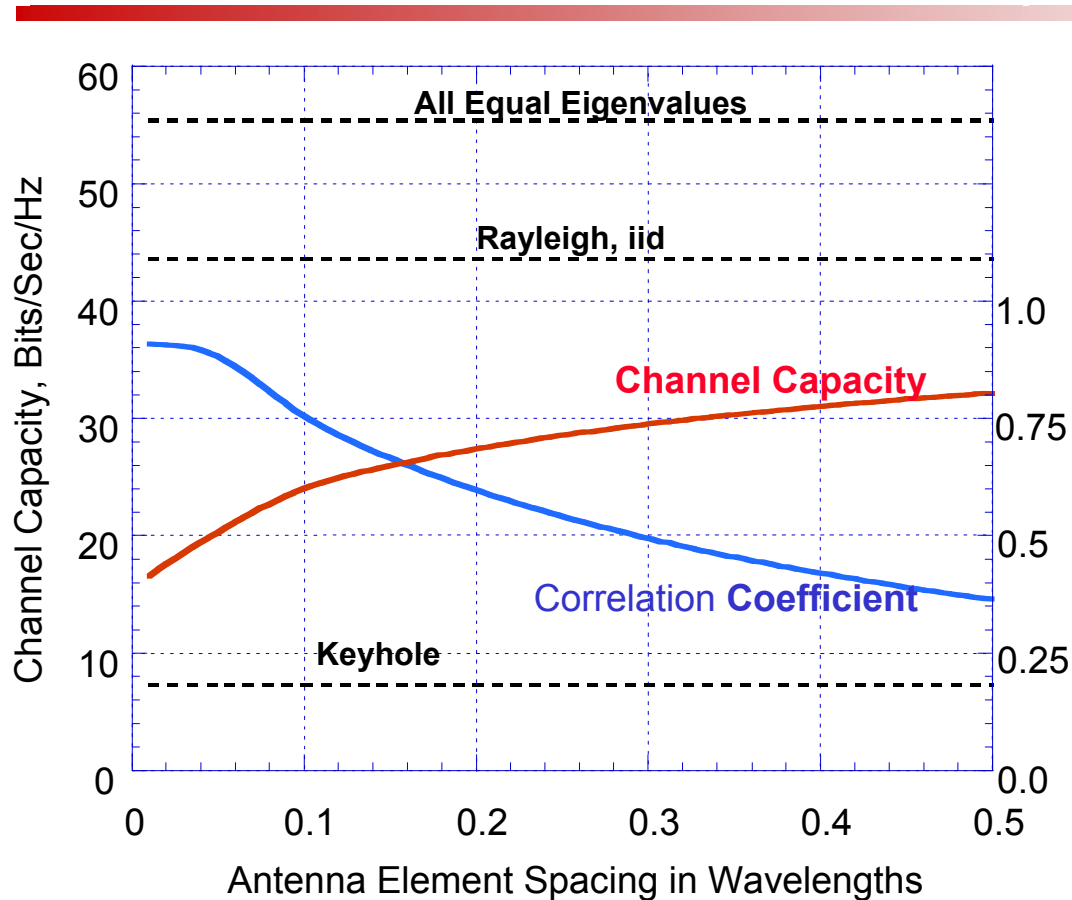

- 10000 Wavelengths from Transmitter to Receiver.
- Scatterers Equally Spaced in a Circle around Receiver, 1000 Wavelength Radius
- All waves propagating in the horizontal Plane
Vertically Polarized
- Antenna Elements are all vertical, thin, half-wavelength dipoles, arranged in a regular square array.
- Transmitter Elements are spaced by 25 wavelengths
- Look out for Supergain (Precise Channel Knowledge.)

Measured: BLAST Capacity vs. TX spacing, 4 x 4

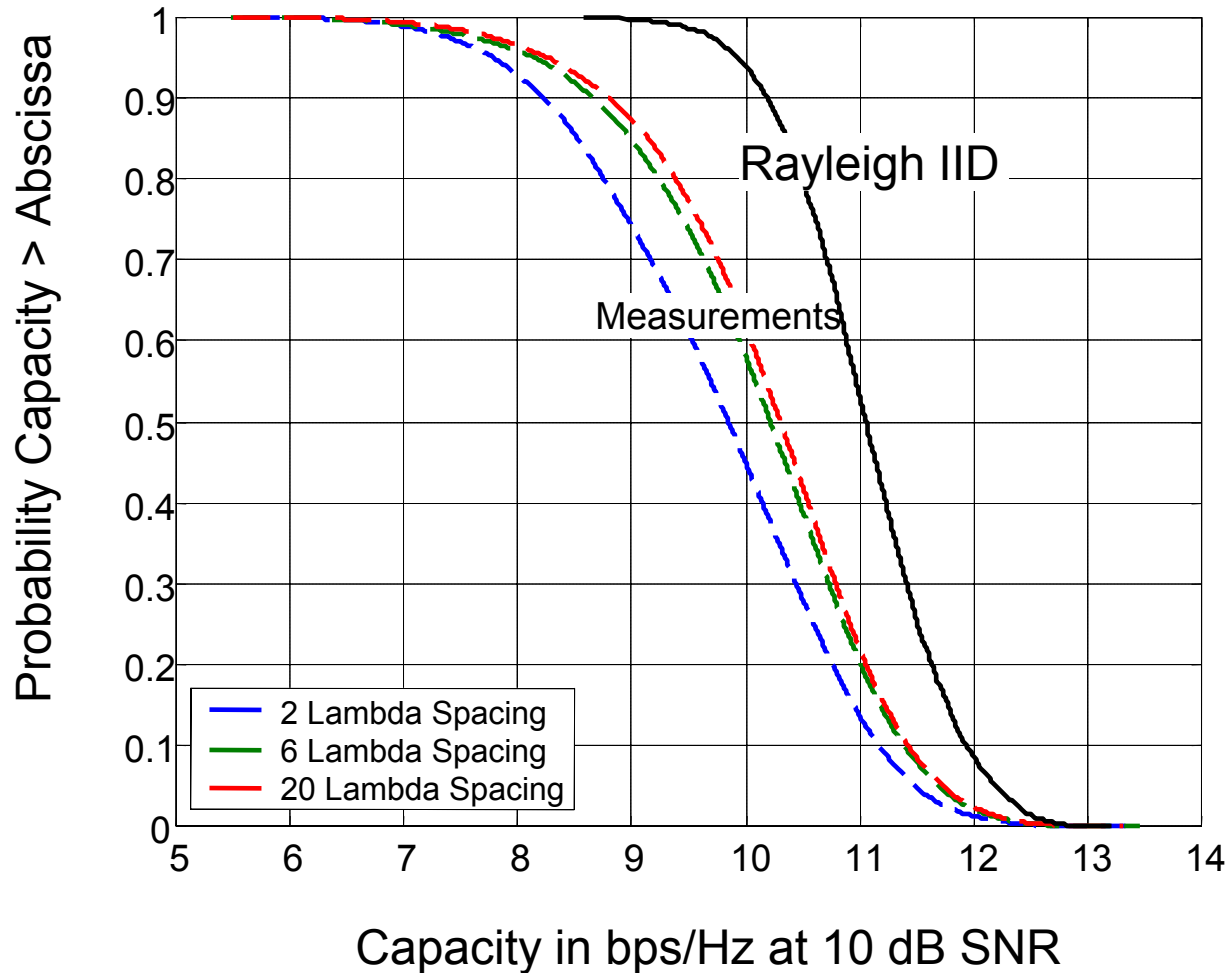

Ongoing Work

Additional narrowband measurements in suburban and urban environments using smaller antenna arrays,

**0.1, 0.2, 0.4, 0.8 lambda spacing at receiver
<1.0 lambda at transmitter**

Broadband MTMR sounder is in calibration.

10 Mchip/sec 16×16 MTMR sounder built by ITS* for joint work.

Collected data is being analyzed in support of model development

* Institute for Telecommunications Science, Boulder, CO.

Conclusion (urban)

- **Capacity Survey Performed in Manhattan with high base, 16 Tx 16 Rx**
- **Lower capacity as Tx antennas are brought closer**
- **Measured capacity is a large fraction of capacity of Rayleigh iid channel**

Array Size	% of Rayleigh IID
2 Tx 2 Rx	99 %
4 Tx 4 Rx	90 %
16 Tx 16 Rx	80 %

Conclusion (urban)

- Terrific BLAST capacity found in urban environments,
>90% of theoretical max with 4x4
- Rich data set will support modeling and standards work

Array Size		Measured median capacity (bps/Hz at 10 dB SNR)	Theoretical median capacity (bps/Hz with Rayleigh iid at 10 dB SNR)
1Tx	1Rx	3.46	3.46
2 Tx	2 Rx	5.8	5.88
4 Tx	4 Rx	10.3	11.1
16 Tx	16 Rx	32	43.7

Wideband V-BLAST

With a narrowband receiver, the signal width is constrained by the coherence bandwidth of the channel. With the ever-growing push for higher data rates, it is desirable to lift this limitation.

If this constraint is violated, the channel introduces **Inter Symbol Interference and the performance of a narrowband receiver degrades rapidly.**

A Wideband BLAST Rx architecture

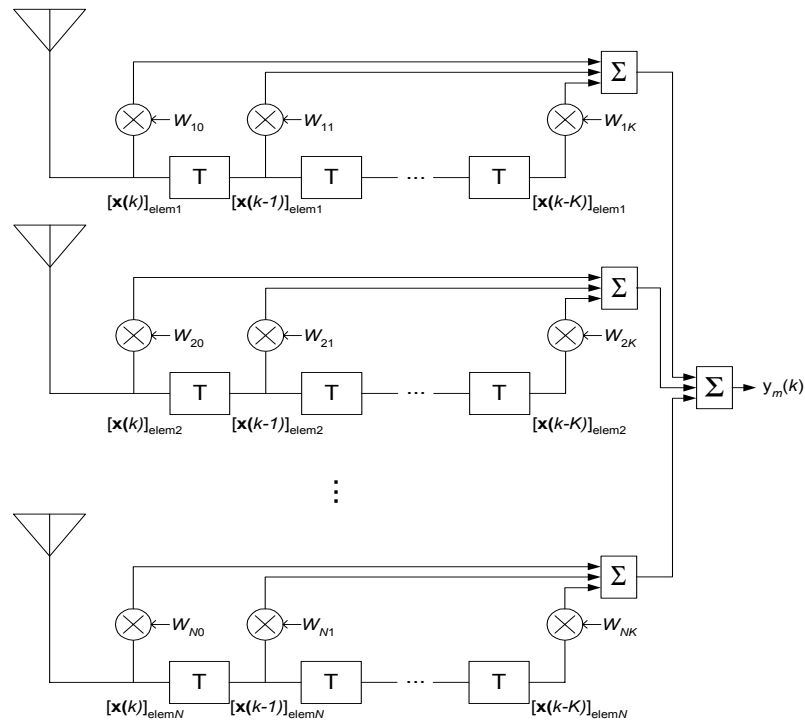

- **Linear space-time processing: can be optimized with MMSE criterion**
- **Important issues: synchronization, convergence, training**

Performance of Wideband MMSE Rx

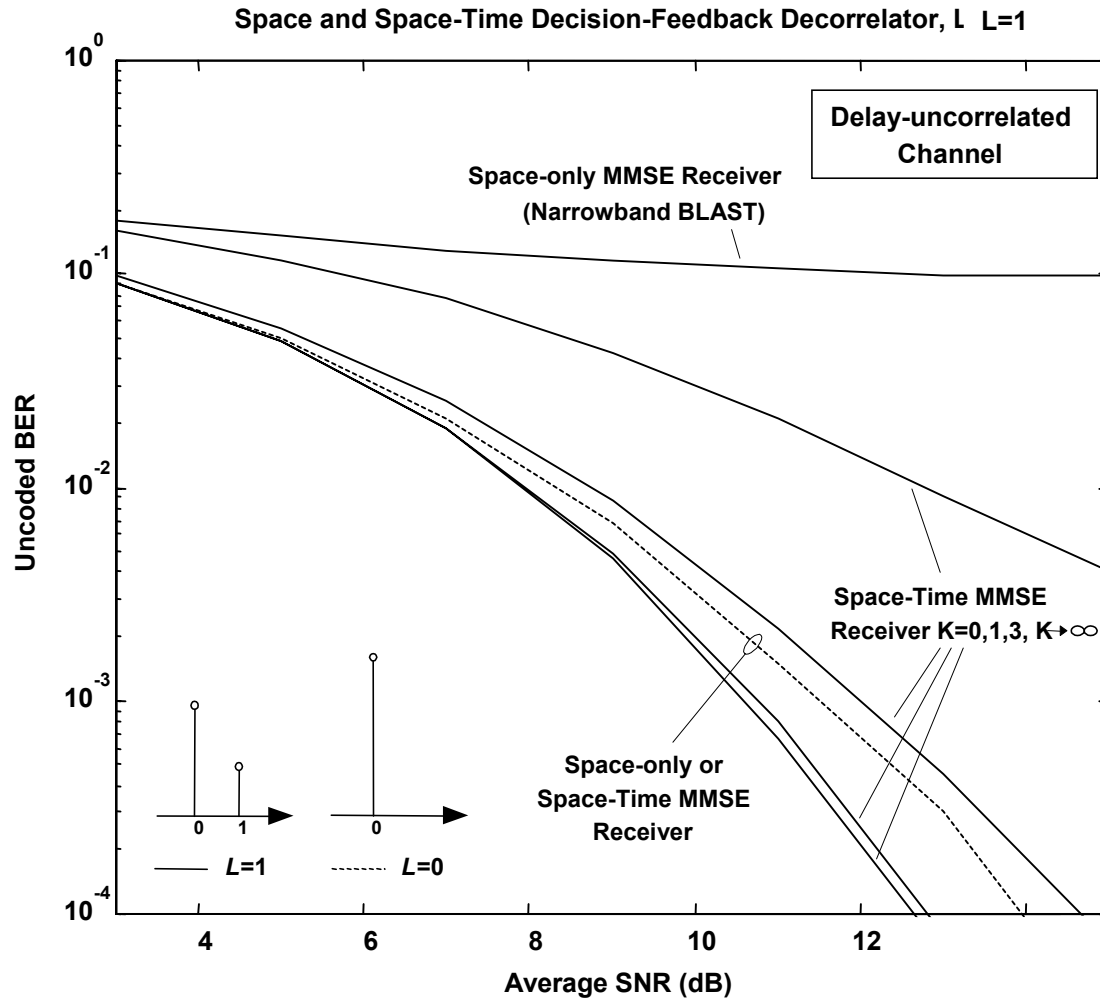

Small number of receive antennas

- **Applications such as:**
 - fixed wireless
 - indoor LANS
 - mobile laptops**may allow for large antenna configurations at the receiver**
- **However, today's cellular handsets can only afford a very small number of antennas (typically just 1), due to size, power and cost constraints**

There is a need for efficient techniques that only employ many antennas at the transmitter (such as in downlink cellular transmission)



A hierarchical view of wireless terminals

- Handsets:



keep shrinking in size, multiple antennas (even 2) seem to be problematic

- PDA's:



size remains fixed (or even increases)
2 antennas may be a reasonable design



- Laptops:



more room for antennas. Multiple antennas combined with BLAST-type processor may offer high data rates (see ORINOCO product family)

Space-Time Spreading

- A “baby-BLAST” technique suitable for current 3G W-CDMA systems:

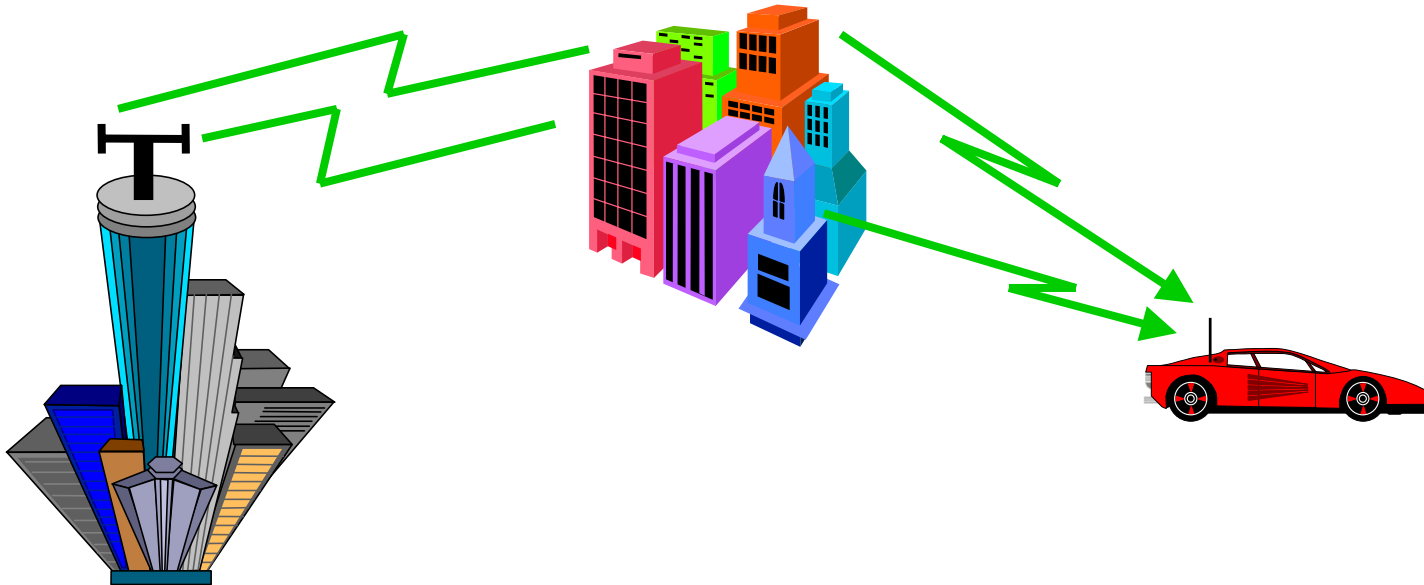

- Based on a “transmit diversity” principle

STS Transmitter architecture

- Each user's sub-streams are multiplexed as follows:

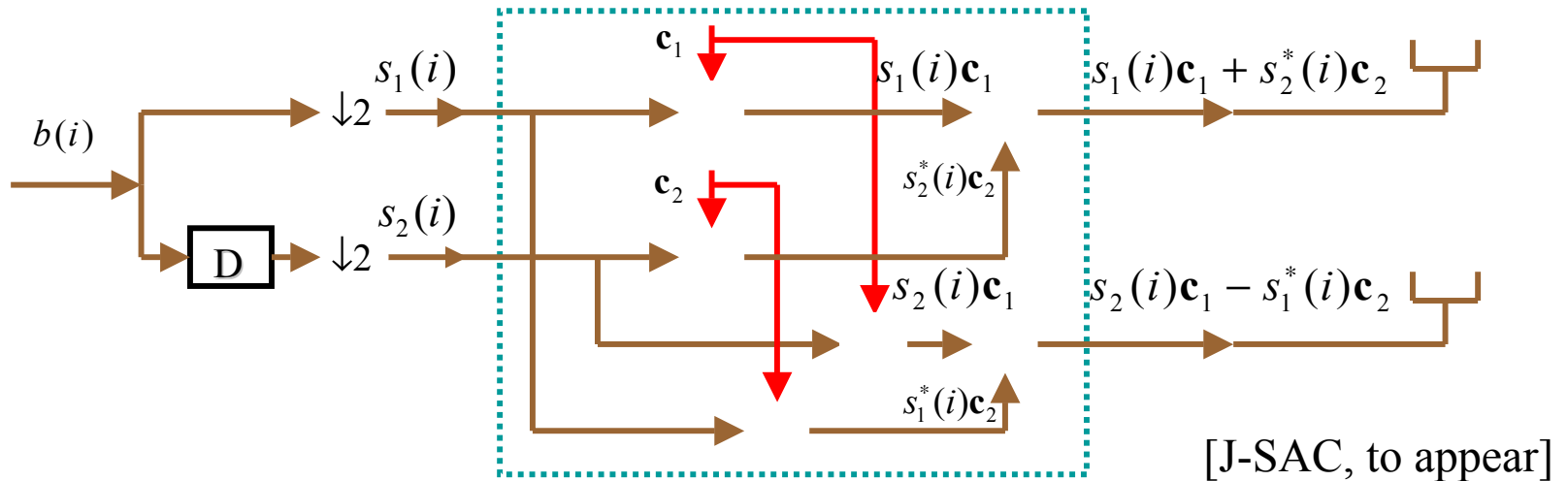

$s_1(i)$ and $s_2(i)$ are odd and even samples from the same user's data

c_1, c_2 are double length but are used for 2 sub-streams,

\Rightarrow

no redundancy

STS Receiver structure

- Simple MF-type processing yields:

$$\text{Re} \{ \mathbf{H}^H \mathbf{d}(i) \} = \left(|h_1|^2 + |h_2|^2 \right) \mathbf{s}(i) + \mathbf{v}'(i)$$

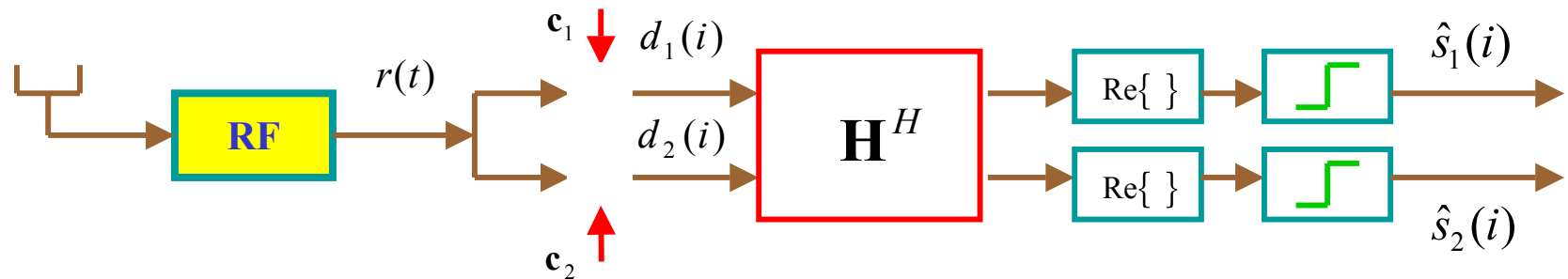

⇒ Provides full **2-branch diversity** combining at the receiver!

The case of complex user data can be equally handled
(for $M=2$)

Shannon capacity

- The STS scheme (or its non-spread counterpart, known as the Alamouti space-time coding scheme), achieves the following Shannon capacity:

$$C_{\text{STS}} = \log_2 \left(1 + \frac{\rho}{2} \sum_{i=1}^2 |h_i|^2 \right)$$

- Notice that this expression is identical to the **BLAST (2,1) capacity (!)**:

$$C_{\text{STS}} = C_{21} = \log_2 \det \left(\mathbf{I}_N + \frac{\rho}{M} \mathbf{H} \mathbf{H}^\dagger \right) \Big|_{M=2, N=1}$$

- Moreover, in achieving this capacity, STS
 - uses temporal-only coding, in a disjoint fashion among sub-streams
 - requires no channel knowledge or feedback from the receiver

BALST for UMTS Background

- **High speed data packet access (HSDPA) provided over the downlink shared channel (DSCH) in UMTS.**
- **Multiple code channels for a single user.**
- **Time-multiplexing between users.**
- **Rate-adaptation so that users with higher SINR receive higher data rates.**
- **Goal: enhance the HSDPA system using multiple antennas at the transmitter and receiver [Multiple-input multiple-output (MIMO) techniques].**
- **Standards note: MIMO has been approved as a work item with March 2002 completion date.**

MIMO in UMTS: Update and Status

- BLAST (MIMO) technologies proposed to **3GPP** standards body for use in high speed downlink packet access.
- **Link and system level simulation** results show promise of MIMO technologies.
- **MIMO** text has been **included** in the technical report to be submitted to the **March 2001 RAN** plenary meeting for approval to become a **work item for UMTS Release 5** (scheduled to be completed by March 2002).

Transmitted signal Conventional HSDPA (single transmit antenna)

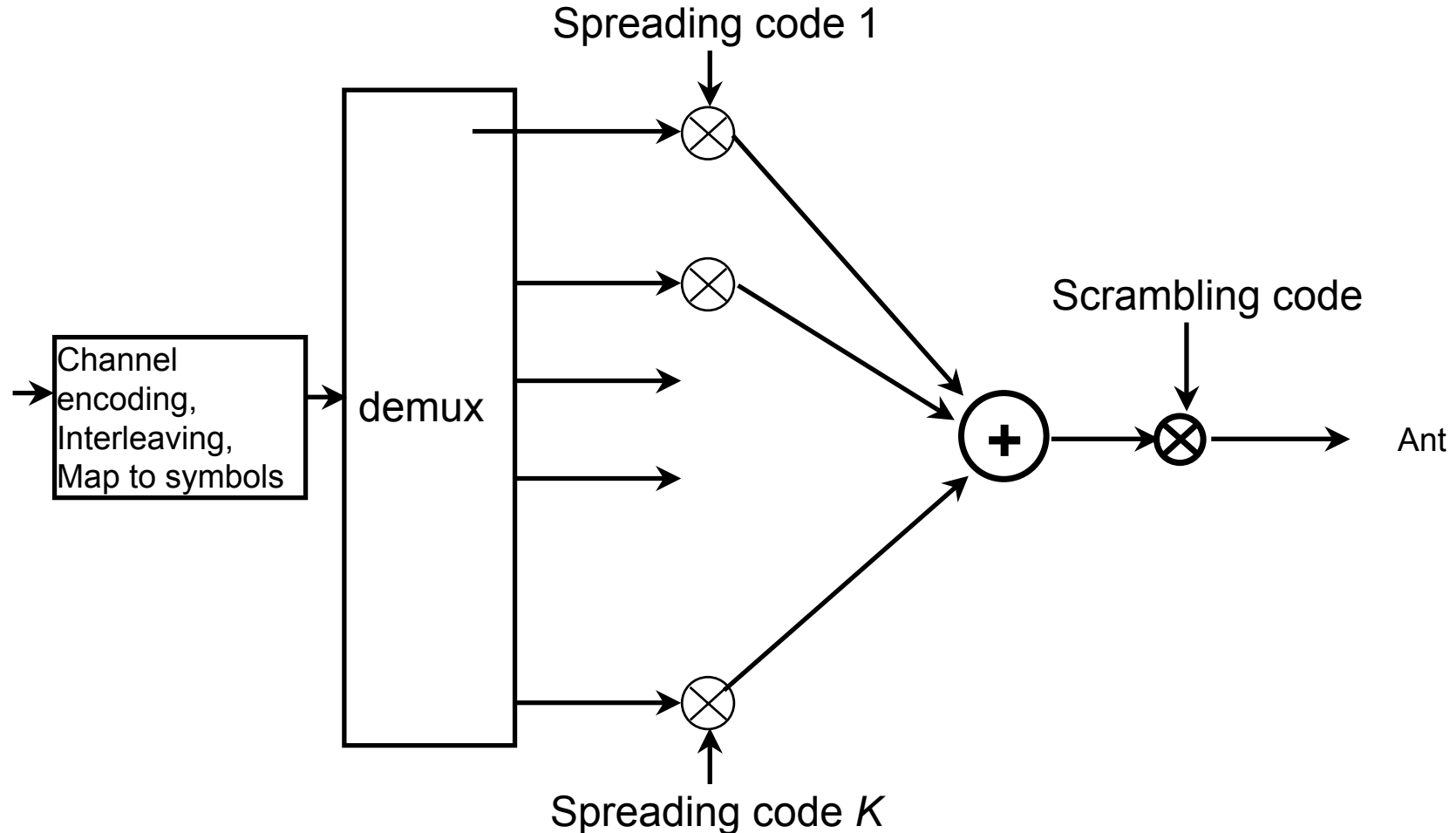

Transmitted signal

MIMO transmission with M antennas

- Each spreading code modulates M substreams

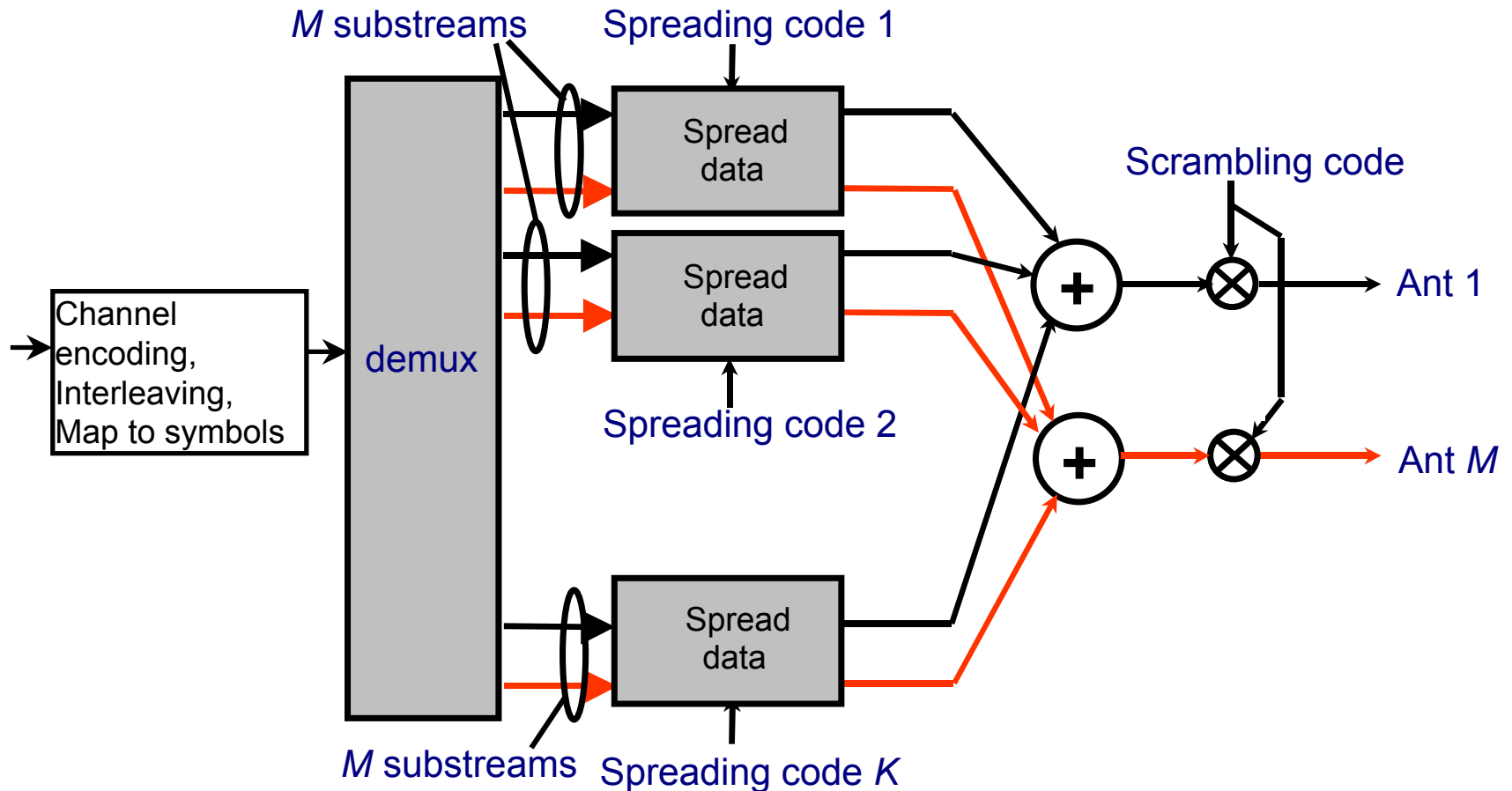

MIMO in UMTS: Technology Overview

- Extension of BLAST to **multicode CDMA** transmission
 - fat pipe: multiple CDMA codes assigned to one user
 - each **code is re-used M times** (M is number of transmit antennas)
 - multiple antennas and BLAST processing used at receiver to resolve spatial interference

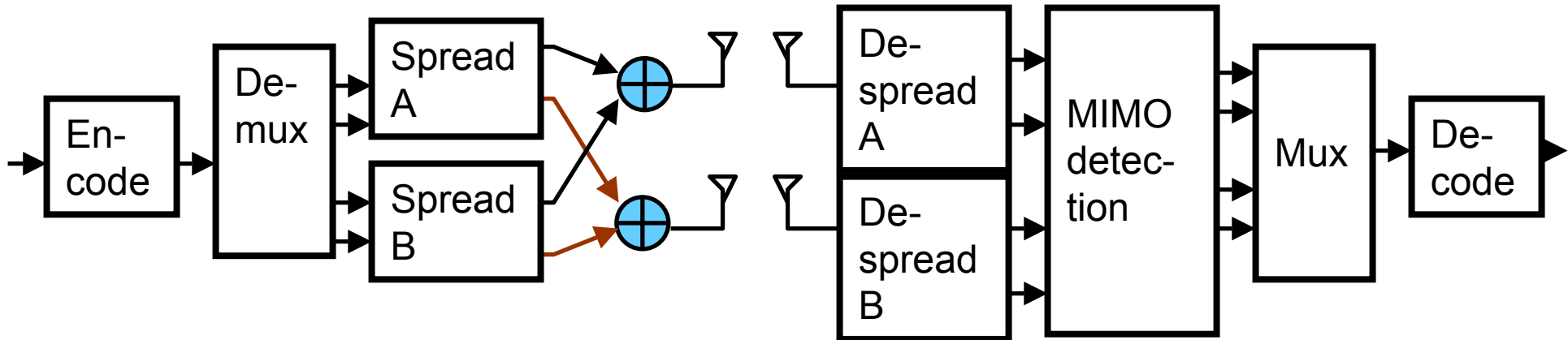

Transmission architectures

# ants	TX technique	code rate	modulation	rate per substream	# sub- streamsrate	total
1	Conv.	3/4	64QAM	540kbps	20	10.8Mbps
2	MIMO	3/4	8PSK	270kbps	40	10.8Mbps
2	MIMO	3/4	16QAM	360kbps	40	14.4Mbps
4	MIMO	~1/2	QPSK	135kbps	80	10.8Mbps
4	MIMO	3/4	QPSK	180kbps	80	14.4Mbps
4	MIMO	3/4	8PSK	270kbps	80	21.6Mbps

All options use $K = 20$ spreading codes.

Receiver architecture

- Multiple antennas and space-time processing used at receiver to resolve spatial interference.
- Space-time processing can be maximum likelihood or VBLAST.

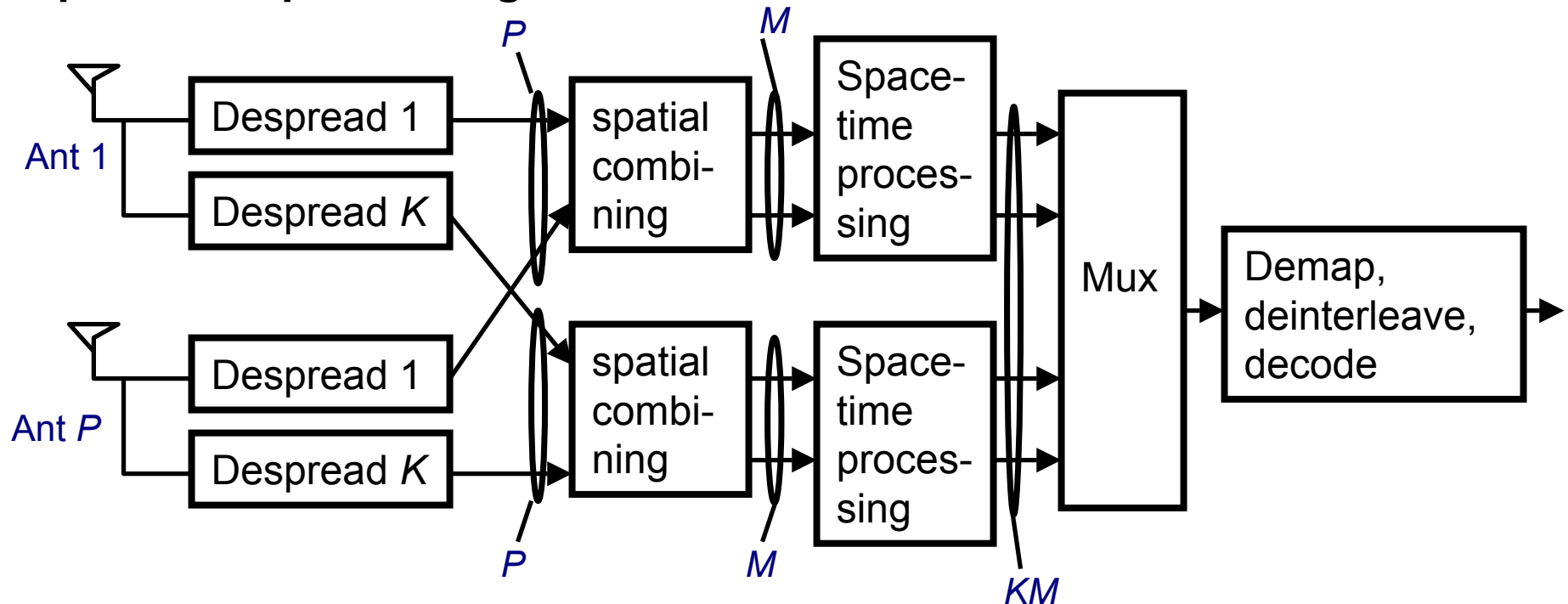

MIMO in UMTS: Link level simulation results

- Assumptions:
 - Turbo coding
 - 20 codes
 - 3km/hr
 - flat fading
 - known channel

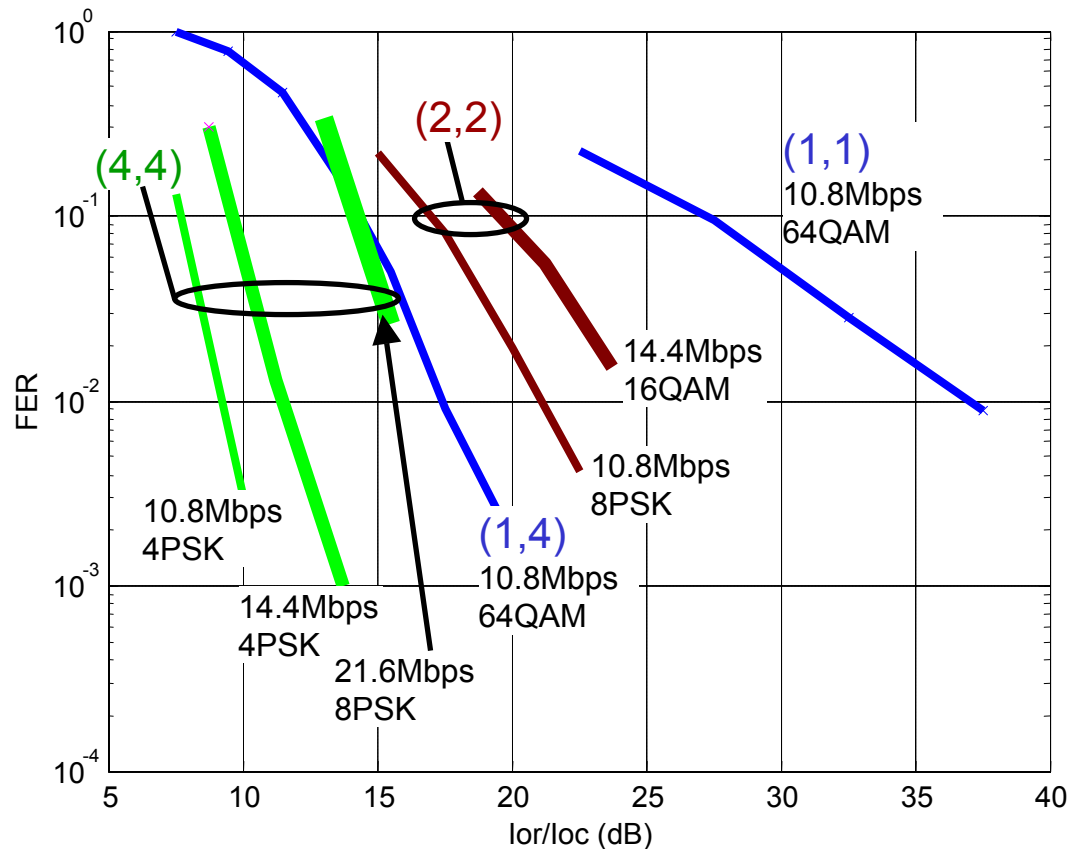

Link level simulation results

- Assumptions:
 - Turbo coding
 - 3km/hr
 - flat fading
 - known channel
 - uncorrelated spatial fading

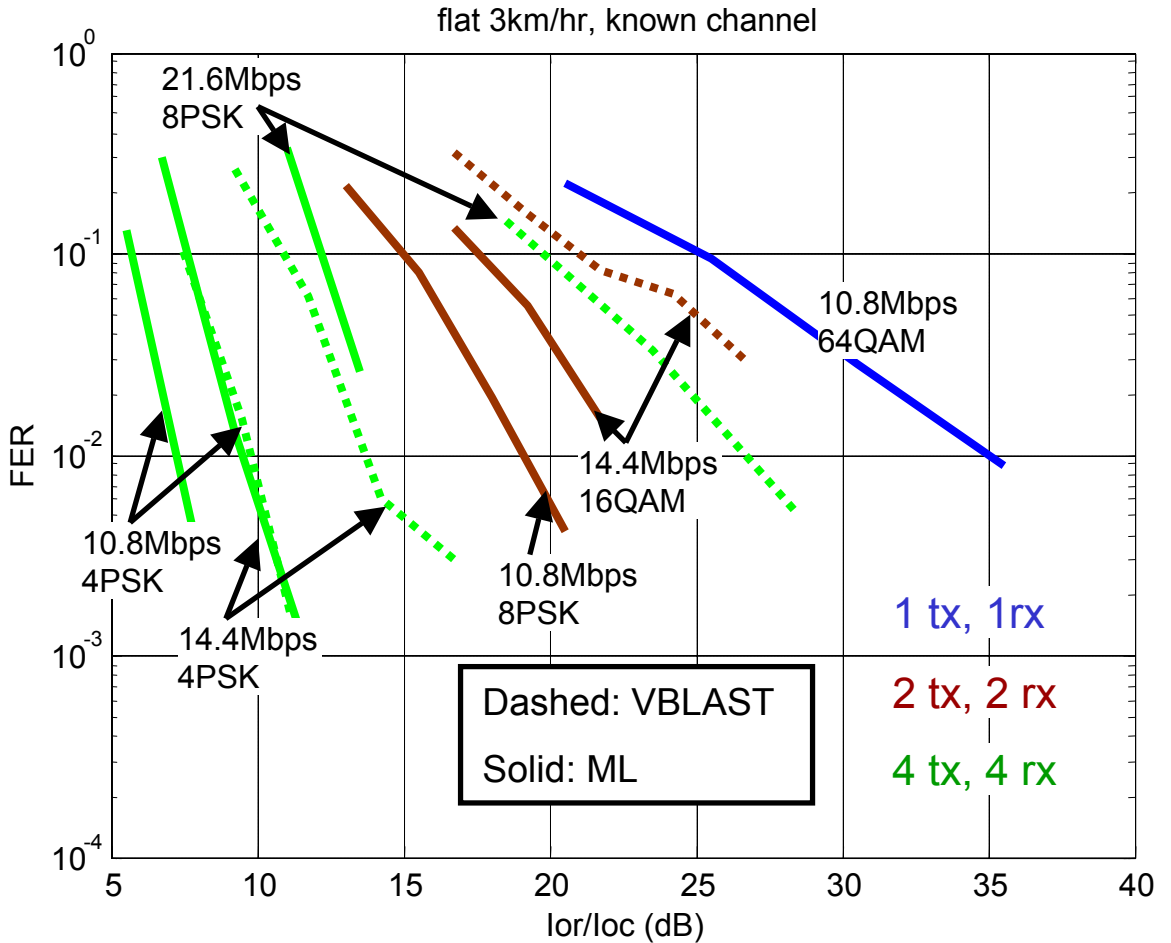

Additional link level results

- **No significant performance degradation due to**
 - **Faster Doppler speeds (up to 30km/hr) and/or**
 - **Non-ideal channel estimation**

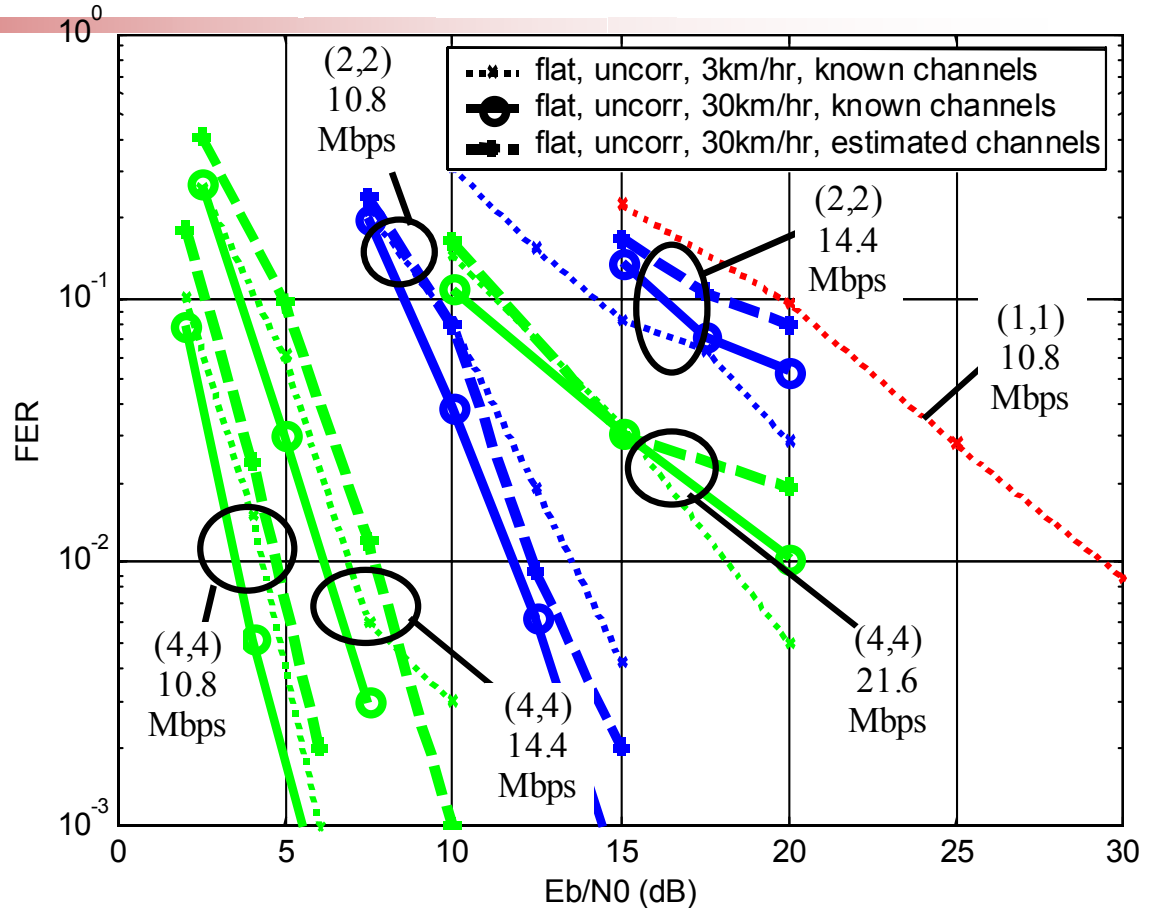

Additional link level results

- **Effects of spatial correlation**
 - minimal degradation for 2 transmitter MIMO

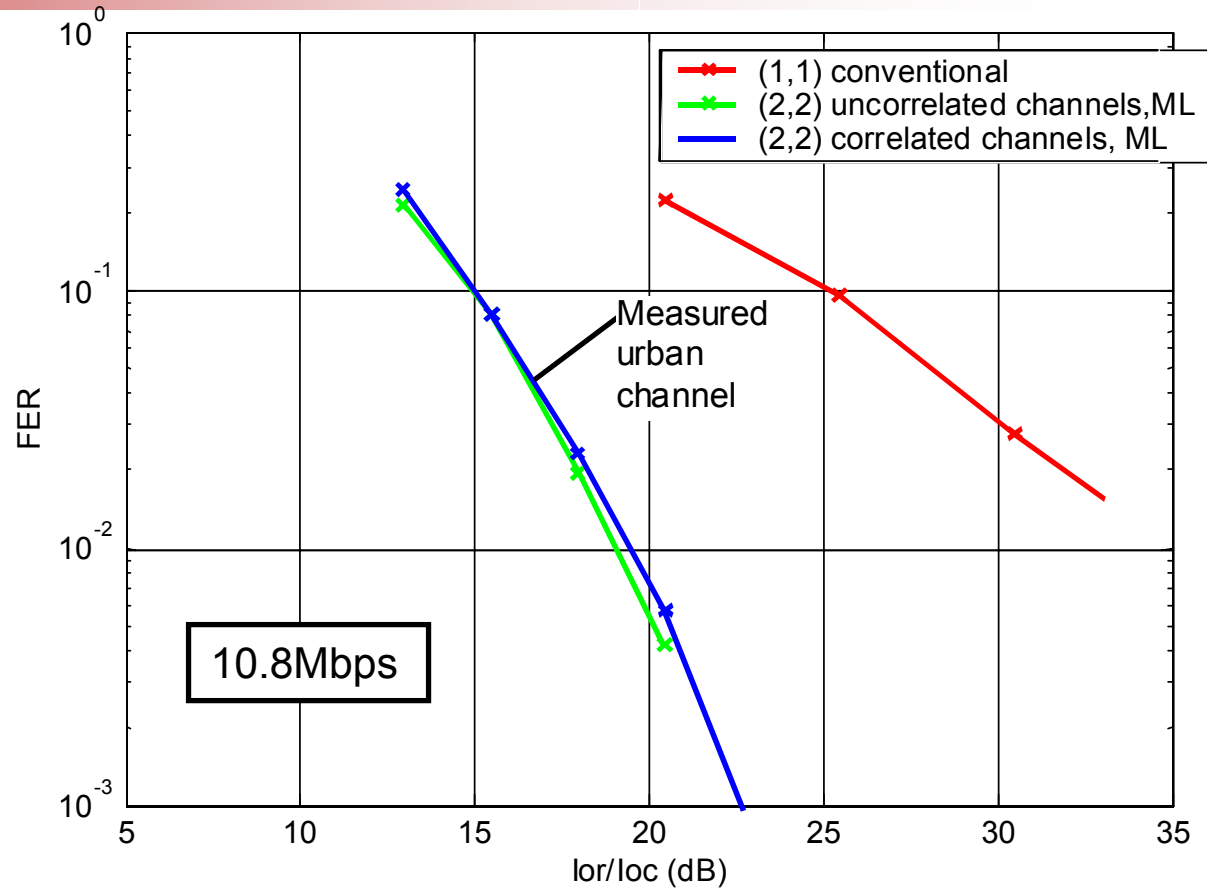

Additional link level results

- **Effects of spatial correlation**
 - performance for 4 transmitter MIMO can be improved by using 2 transmitters.

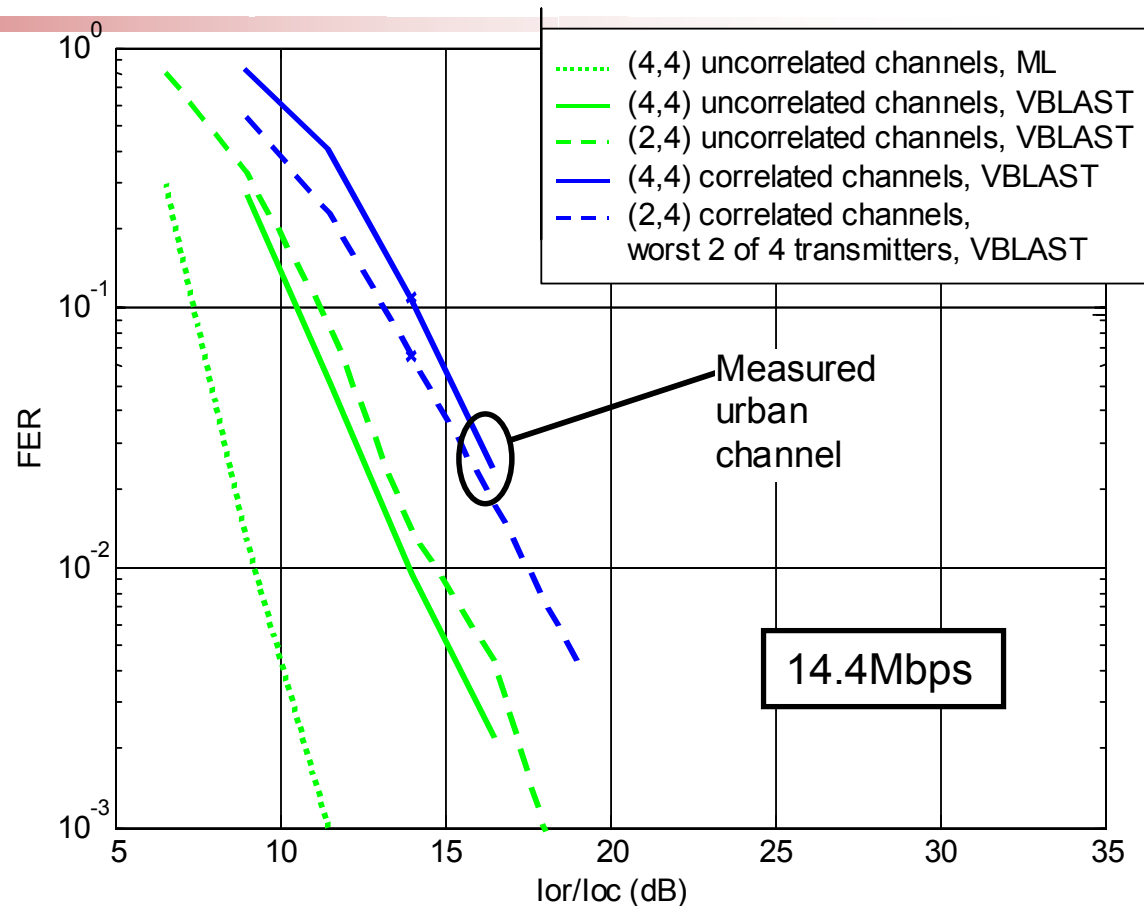

System level simulation results

- **Assumptions:**
 - 19 cell system, 3 sectors/cell
 - consider center cell; max power tx from other cells
 - Round robin scheduling, transmit to one user at a time.
 - RAN-specified packet-call model: packet-calls with Pareto dist. (mean 210Kbytes), interarrival time with geometric dist. (mean 5 seconds).
 - same link level assumptions as before
 - “optimum” transmission for each user: MIMO transmission for users with high lor/loc, selection diversity for those with low lor/loc.
- **Average sector throughput for fully utilized system:**
 - (1,1), 1.96 Mbps (20 users), 64-QAM, 3/4 convolutional code
 - (2,2), 3.24 Mbps (20 users), 8-PSK, 3/4 convolutional code
 - (4,4), 5.37 Mbps (40 users), QPSK, 1/2 conv. code with puncturing

Practical considerations at base station

- **Orthogonal pilot sequences for each transmit antenna: backwards compatible**
- **Total transmit power is same as conventional case; each antenna transmits with $1/M$ power.**
- **For uncorrelated fading, 10 lambda spacing is sufficient. Using dual polarized antennas, 4 antennas fit in 1.5m.**

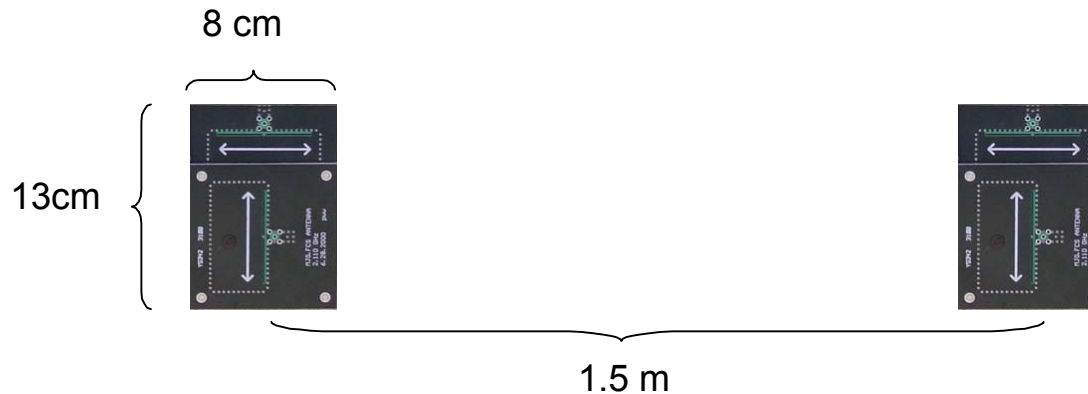

Antennas used in MIMO channel measurements

Practical considerations at the terminal

- For uncorrelated fading, $1/2$ lambda spacing is sufficient because of local scatterers.
- Each antenna requires RF/IF chain. Significant cost savings using direct conversion (homodyne) solutions.
- 20% and 70% of baseband processing used by VBLAST detector and turbo decoder, respectively, for (4,4) receiver. Overall processing is within range of existing hardware technologies.

Antennas used in MIMO channel measurements

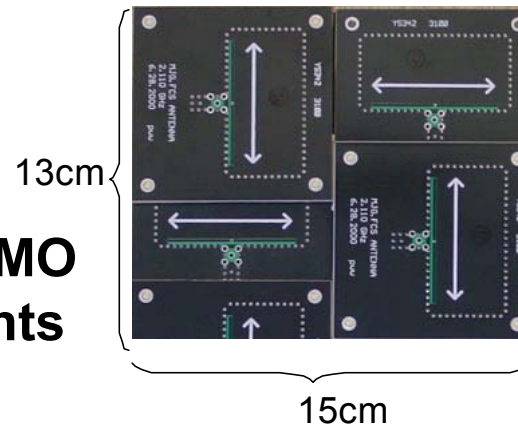

MIMO in UMTS: Conclusions

- MIMO achieves **high data rates** (10.8 Mbps) more **efficiently** than conventional diversity techniques (QPSK Vs. 64 QAM)
- MIMO achieves **higher peak data rates** (up to 21.6 Mbps).
- Future work:
 - alternative transmission/detection/decoding techniques
 - closed loop MIMO techniques
 - equalization for frequency selective fading
 - reduced-complexity receiver processing

CONCLUSIONS

- **BLAST** overcomes conventional limits
- Capacity gains can be **very large**
- **Demonstrated** experimentally indoors
- **Very large measured urban and suburban capacities**
- **Practical** implementations achieve significant fraction of capacity: **V-Blast, T-BLAST**
- **Near term impact on CDMA2000 and UMTS**