

Efficient Integration of Multi-hop Wireless and Wired Networks with QoS Constraints

Yigal Bejerano
Information Sciences Research Center,
Bell Laboratories, Lucent Technologies,
600 Mountain Avenue, Murray Hill, NJ 07974

ABSTRACT

This work considers the problem of designing an efficient and low-cost infrastructure for connecting static multi-hop wireless networks with wired backbone, while ensuring QoS requirements such as bandwidth and delay. This infrastructure is useful for designing low cost and fast deployed access networks in rural and suburban areas. It may also be used for providing access to sensor networks or for efficient facility placement in wireless networks. In these networks some nodes are chosen as access points and function as gateways to access a wired backbone. Each access point serves a cluster of its nearby user and a spanning tree rooted at the access point is used for message delivery. The work addresses both the design optimization and the operation aspects of the system. From the design perspective, we seek for a partition of the network nodes into minimal number of disjoint clusters that satisfy multiple constraints; Each cluster is required to be a connected graph with an upper bound on its radius. We assume that each node has a weight (representing its bandwidth requirement) and the total weight of all cluster nodes is also bounded. By breaking the problem into two sub-problems and solving each one separately, we propose polynomial time approximation algorithms that calculate solutions within a constant factor of the optimal ones. From the operation viewpoint, we introduce an adaptive delivery mechanism that maximizes the throughput of each cluster without violating the QoS constraints.

Categories and Subject Descriptors

C.2.1. [COMPUTER-COMMUNICATION NETWORKS]:
Network Architecture and Design – Wireless communication

General Terms

Algorithms, Design, Theory.

Keywords

Wireless Access Network, Sensor Networks, Unit Disk Graphs, Clustering, Approximation Algorithms.

Permission to make digital or hard copies of all or part of this work for personal or classroom use is granted without fee provided that copies are not made or distributed for profit or commercial advantage and that copies bear this notice and the full citation on the first page. To copy otherwise, to republish, to post on servers or to redistribute to lists, requires prior specific permission and/or a fee.

MOBICOM'02, September 23–28, 2002, Atlanta, Georgia, USA.
Copyright 2002 ACM 1-58113-486-X/02/0009 ...\$5.00.

1. INTRODUCTION

The tremendous advance of wireless communication technologies has prompted the development of new wireless applications. Among these new applications we found the broadband wireless access (BWA) systems [1] and the wireless sensor networks [2, 3]. BWA systems provide broadband access for residential customers for both telephone and Internet connectivity and they are easily deployed in areas where the existing communication networks cannot support the bandwidth demands. Wireless sensor networks, like the WINS [2], provide monitoring and control capacities over large areas for monitoring applications, like transportation, manufacturing, health care and security monitoring. These networks are composed of large number of low power sensors that collect measurement, acoustic or video information and send it to monitoring centers. In both applications, most of the communication is between the wireless nodes and stations outside the wireless networks, *i.e.*, monitoring centers or Internet servers. This raises the need for efficient connectivity between the wireless nodes and the fixed networks that minimizes the number of direct connections while satisfying *Quality of Service* (QoS) constraints.

Currently, in sensor networks some nodes are selected as access points between the sensor network and the fixed backbone [3]. However, to the best of our knowledge there is no rigorous method for selecting these nodes. BWA systems use a cellular-like approach, where a single access point provides wireless connectivity to a group of static users in its transmission range. Such an approach is suitable for urban areas with dense user population. However, it may be inefficient in rural and suburban areas with sparse population, where the number of users served by a single access point is low. Although the user to access point ratio can be improved by increasing the transmission power of both the access points and the users, the latter causes significantly higher energy consumption by the wireless stations, increases the wireless channel interference and requires more expensive hardware. These drawbacks make the cellular-like approach inefficient solution for sensor networks and for BWA systems in rural areas. In [4], Beyer *et al.* presented a low-cost Internet access infrastructure for geographically scattered communities termed a *rooftop community network*. In their scheme, the community houses are equipped with simple antennas and create a multi-hop wireless network. Some of the nodes, termed *access points*, are directly connected to a backbone network and function as gateways to access the Internet. This approach gains a lot of attention in the recent years and some community networks have already been launched in several regions in U.S.A. [5].

This work uses the concept of *community access network* for constructing an efficient and low-cost infrastructure that connects static wireless networks with wired backbone network while ensuring QoS requirements such as bandwidth and delay. The proposed infrastructure can be used for broadband access control, collecting monitoring information of sensor networks, or for facility placement when the provided services need to satisfy QoS constraints. Our scheme divides the network nodes into *clusters* and selects a single access point node at each cluster. The access point functions as gateways to access the wired backbone for all its cluster nodes. At each cluster, a spanning tree rooted at the access point is used for message delivery, where the tree's internal nodes (beside the access point) serve as relays for the benefit of the distinct stations. This tree-based approach simplifies the routing [6] and enables us to maximize the network utilization while ensuring the QoS constraints. By selecting a small number of clusters, the number of required access points as well as the system cost are reduced. However, for operational considerations and for QoS assurance the clusters must satisfy several constraints: The clusters should be disjoint and contain all the network nodes. Each cluster must induce a connected graph with fixed bound, R , on its radius for multi-hop routing with bounded propagation delay. For QoS based access, there is a bound on total bandwidth requirement of all the nodes in a cluster and a node may serve as relay only for a limited number of users. Our work addresses both the design and the operation aspects of the proposed infrastructure. We consider the *clustering problem* of minimizing the number of clusters that satisfy the above constraints and we present polynomial-time approximation algorithms that guarantee solutions within a constant factor of the optimum ones. We also introduce an adaptive delivery mechanism that maximizes the throughput of each cluster without violating the QoS constraints.

Clustered and hierarchical structures are widely used in communication networks [7] and numerous algorithms for low-diameter graph decomposition are described in the literature [8, 9]. Most of these studies model the communication networks as arbitrary graphs and they do not consider practical topologies of wireless networks. In wireless networks clustering techniques are extensively used for routing [10, 11, 12], location management and facility location [13] (see also [14]). Most of these schemes proposed heuristics for dividing the wireless network into clusters with bounded diameter when ignoring the clusters' sizes. It is usually the case that the number of calculated clusters is evaluated by simulations and no guarantee, in comparison to the optimal solution, is proven. Recently, in [15], Banerjee and Khuller presented a clustering scheme that partitions a given wireless network to connected clusters that satisfy minimum and maximum size constraints. In their scheme, a node may be included in a constant number of clusters and the intersection of two clusters may include a small number of nodes. To the best of our knowledge, there is no clustering algorithm that satisfies all the requirements of our clustering problem.

In this paper, rather than addressing the combined problem, we break it into two sub-problems, which are both NP-hard. The first one seeks to find minimal number of disjoint connected clusters that contain all the nodes and satisfy the radius constraint. For this problem we present "heavy" and "light" algorithms, in terms of time complexity, with different approximation ratios. The "heavy" algorithm uses the *shifting strategy* of Hochbaum and Maass [16] and allows us

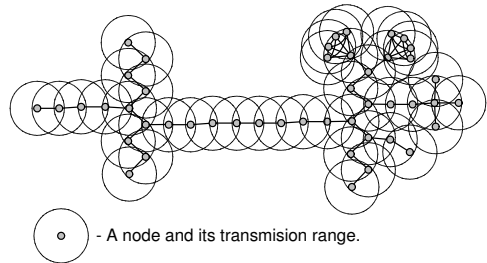

Figure 1: An example of a wireless network and its unit disk graph representation.

to control the complexity and the quality of the solution. The "light" algorithm is based on geometric properties of unit disk graphs and guarantees an approximation ratio that is proportional to the maximal radius R , independent of the network size. After finding a set of clusters with bounded radius, clusters that violate the weight constraint are further divided by a weight partition algorithm based on the scheme of Banerjee and Khuller in [15]. The weight partition algorithm guarantees a 3-approximation ratio. As a result, the final solution satisfies the clustering constraints and its size is within a small constant factor of the optimum solution. Our simulations show that the proposed algorithms yield efficient partitions which are close to the optimum.

Due to space limitation, we present in this paper only sketches of the proofs and more details can be found in [17]. There we also present the clustering problem as a variant of the *capacitated facility location problem* (CFLP) [18] with additional constraints.

2. THE NETWORK MODEL

We consider a static multi-hop wireless network represented by an undirected graph $G(V, E)$. Each node $v \in V$ represents a radio transceiver with a unique identification number (ID). At any given time a transceiver may either transmit or listen to a single wireless channel. The bandwidth of every wireless channel is W and it is divided into time slots of length Δ . Each node $v \in V$ has a circular transmission range with radius 1 and the *neighborhood* of v , denoted by $N(v)$, is the set of nodes that reside within its transmission range. Thus, there is a bi-directional wireless link between v and every node $u \in N(v) - \{v\}$, which is represented as an edge $(u, v) \in E$. Consequently, our network model is similar to the proximity model of unit disk graphs that is defined in [19]. An example of such graph is given in Figure 1. In the following, we use this simple network for illustrating the properties of the proposed algorithms.

In our model, the *shortest path* between nodes $u, v \in V$ is the path with the minimum number of hops between them and their *distance*, $d(u, v)$, is the number of hops in this path. Any subset of nodes $C \subseteq V$ is called a *cluster* and assume that there is a cluster-head $y \in C$ at each considered cluster C . The cluster nodes and the links between them define the *cluster graph* $G_C(C, E_C)$, where $E_C = \{(u, v) | u, v \in C \wedge (u, v) \in E\}$. A cluster is called *connected* if its corresponding cluster graph is connected. We denote by $d_C(v, u)$, $v, u \in C$, the shortest path between u and v in the cluster graph and the *cluster radius* is the maximal distance from y to any other node $v \in C$, i.e., $\max_{v \in C} d_C(y, v)$. In addition, every node $v \in V$ has a positive weight $w_v \ll W$

that represents its bandwidth requirement and we denote the total weight of a cluster C by $W_{sum}(C) = \sum_{v \in C} w_v$.

Let T be a spanning tree of a cluster graph $G_C(C, E_C)$ rooted at the cluster-head $y \in C$. The i -th level of the tree T is the set of nodes with hop distance i from y along the tree T and the *depth* of T is the index of its farthest level. A tree T is called a *shortest-path (SP) tree* if it is composed of the shortest paths from its root, y , to any other node $v \in C$. In this case the depth of T is also the cluster radius.

For any positive integer k , the k -neighborhood of a node v , denoted by $N_k(v)$, is the set of nodes with distance at most k from v in G , i.e., $N_k(v) = \{u | v \in V \wedge d(u, v) \leq k\}$. We define the k -th power graph of G , denoted by $G^k(V, E^k)$, as the graph with the nodes V and an edge between every pair of nodes $u, v \in V$ such that $d(u, v) \leq k$ in G . Recall that the k -neighborhood of a node v in G is the neighborhood of v in G^k .

For the sake of completeness we present here several graph theory definitions that we use in the paper. Given an undirected graph $G(V, E)$, an *independent set* (IS) of G is a subset $S \subset V$ such that there is no edge between any pair of nodes in S . In unit disk graph the geographic distance between every pair of nodes in S is more than 1. A *dominating set* (DS) of G is a subset $S \subset V$ such that every node in $V - S$ has at least one neighbor in S and a *dominating independent set* (DIS) of G is a set $S \subset V$ that is both dominating and independent set. An approximation algorithm for an optimization problem Π provides an *approximation factor* of δ if for every instance of Π the solution returned by the approximation algorithm is within a factor of δ from the optimal solution. A *polynomial time approximation scheme* (PTAS) for problem Π is a polynomial time algorithm which for any given instance I of Π and $\epsilon > 0$, returns a solution within a factor of $(1 + \epsilon)$ times of the optimal solution for I .

3. THE SYSTEM DESCRIPTION

3.1 The Multi-Hop System

The aim of the proposed system is providing low-cost connection between a wireless network $G(V, E)$ and a fixed backbone network that satisfies *quality of service* (QoS) constraints. The QoS constraints are given in the form of minimal bandwidth requirements¹, w_v , of every node $v \in V$ and a bound D_P on the message propagation delay. The connection is obtained by equipping some nodes with direct links with a backbone network. Such node, termed *access point*, serve as a gateway between the nodes in its vicinities and the backbone. The efficiency of a proposed system is evaluated by the number of access points that it requires.

In this work we propose to minimize the number of access points by using multi-hop systems. We partition the wireless network into connected clusters and select a *cluster-head* at each cluster that serves as the access point of all its cluster nodes. For message delivery, we construct a spanning tree, termed a *delivery tree*, rooted at the cluster-head, where internal nodes serve as relays for connecting distinct nodes with the access-point. The tree-based delivery mechanism simplifies the message routing [6] and enables us to maximize the network utilization while satisfying the QoS constraints. In Example 1, we illustrate that the multi-hop systems need significantly less access points than the single-hop systems

¹Similarly, the weight may represent a lower bound on the average bandwidth requirement of a considered node.

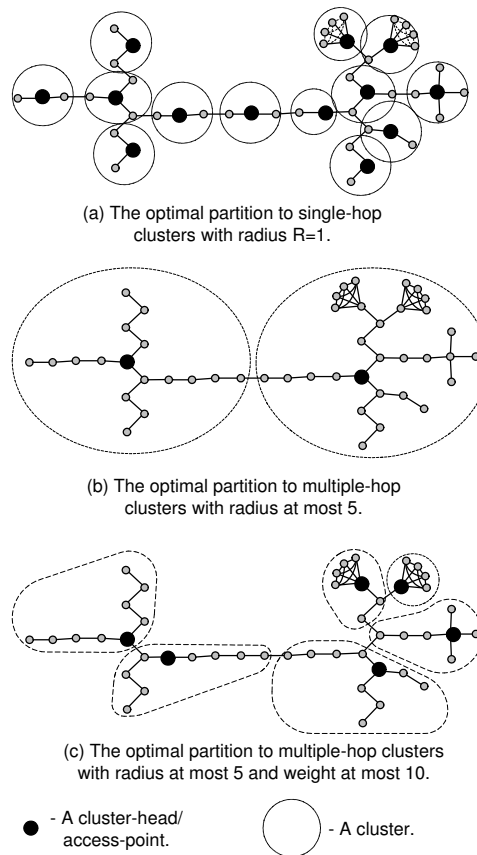

Figure 2: Examples of single-hop and multi-hop systems.

(where each node is included in the transmission range of its access point), even when an access point can serve only small number of users. This observation is also confirmed by our simulations in Section 7.

EXAMPLE 1. Figure 2 presents the optimal single-hop and multi-hop systems for the graph presented in Figure 1. For the multi-hop systems, the cluster radius is bounded by $R = 5$ and the number of nodes in a cluster is bounded by 100 and 10, respectively. In this example, the optimal solutions were found by checking all the possibilities. \square

For designing effective multi-hop systems we should construct two mechanisms: (i) An efficient clustering algorithm that produces a small number of delivery trees that cover all the nodes and satisfy the given QoS constraints. (ii) A delivery mechanism at each cluster that maximizes the cluster throughput without violating the QoS constraints and with efficient channel utilization. In the rest of this section, we describe the delivery mechanism. This description is essential for understanding the constraints of the clustering algorithm, e.g., the maximal radius of a cluster, R . For simplicity, we assume that the upstream and downstream bandwidth requirements of every node are the same.

3.2 The Delivery Mechanism

Consider a cluster $C \subseteq V$ with a delivery tree $T(C, E')$ rooted at an access point $y \in C$ and assume that the tree

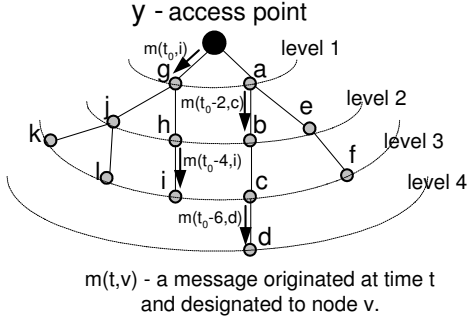

Figure 3: An example of downstream transmissions at a given time slot t_0 .

depth is R . Since, all messages traverse through the access point, the throughput of the cluster is maximized when the access point is busy all the time with efficient data transmission. This goal is obtained by employing collision free transmission scheme, where the access point² coordinates all the transmissions inside the cluster by using slotted channels and polling mechanism. For the clarity of the presentation we assume that the slots are enumerated. Moreover, each node knows its parent and its descendant nodes in the delivery tree.

3.2.1 Downstream and Upstream Delivery

For efficient and simple message delivery, the slots are divided into upstream and downstream slots. Odd slots are used only for downstream data transmission, while upstream data is forwarded only in even slots. Initially, let us describe the downstream transmissions and recall that every downstream message is originated by the access point. Consider a message from the access point y to node u that was originated at time t_0 and traverses along the path $P_{y,u} = \{v_0 = y, v_1, v_2, \dots, v_k = u\}$ in T . At each successive downstream slot, the message is forwarded from its current location to its successive nodes in the path $P_{y,u}$, until it reaches its destination. Thus, at slot t_0 the message is received by node v_1 , at slot $t_0 + 2$ the message is forwarded to node v_2 and so on, until it reaches node u at slot $t_0 + 2 \cdot (k - 1)$. The total propagation delay of the message in the system is $2 \cdot k - 1$ time slots. Since, a node may either receive or transmit at any given time, the delivery mechanism must ensure that when node v_i sends the message to node v_{i+1} , it is not supposed to receive another message. This property is obtained if the access point does not send two messages to the same child, v_1 , in two successive downstream slots.

EXAMPLE 2. Figure 3 presents an example of a delivery tree in which four messages are forwarded simultaneously at a given time slot t_0 . Each message $m(t, v)$ is indicated by its first transmission time t (by the access point) and its destination node v . \square

Upstream transmission is done in a similar manner. The main difference is that upstream messages are originated by cluster nodes, $u \neq y$, and designated to the access point, y . For guaranteeing collision free operation, the access point

²By definition, the access point is a single point of failure since it is the only node in the cluster that is connected to the backbone network. Therefore, a complicated distributed management is not justified.

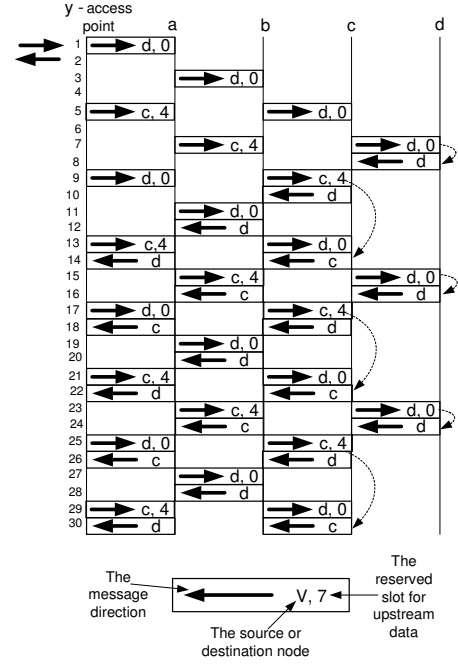

Figure 4: An example of the message delivery of two active sessions during 30 time slots.

allocates for each node *reserved slots* for its upstream transmission. This reserved slot information is piggybacked to the downstream messages sent to each node and it specifies the number of slots that the node should wait before sending its next upstream message. This dynamic slot allocation method enables adaptive and fair bandwidth management that maximizes the cluster throughput. It also satisfies the next property.

PROPERTY 1. *The maximal propagation delay of a message in the wireless network is at most $(2 \cdot R - 1) \cdot \Delta$, when Δ is the duration of a time slot.*

EXAMPLE 3. Figure 4 presents an example of message delivery along a given path $P = \{y, a, b, c, d\}$ during a period of 30 time slots. The access point manages two sessions with nodes c and d , and the bandwidth of each session is $W/4$. Recall that downstream messages carry the destination IDs, while upstream messages contain the source IDs. \square

3.2.2 Synchronization and Channel Allocation

The proposed system maximizes the system throughput by preventing transmission collisions. Thus, at every time slot, each node has to know either its transmission or listening channel. Moreover, two nodes are not allowed to transmit simultaneously on the same channel if they are both neighbors of one of the receiving-nodes. The channel synchronization, however, can be simplified by using the next property of the delivery mechanism.

PROPERTY 2. *At any given time there is at most one transmitting-node at each level of the delivery tree.*

This property results from the fact that at each time slot the access point can either transmit or receive a single message. Thus, for each level i of the tree, we allocate a single

channel, F_i , that is used as the transmission channel by all the nodes in level i . Every non-transmitting node in level i , listens to channel F_{i-1} during downstream slots and to channel F_{i+1} during upstream slots. From Property 2 follows that there are no transmission collisions and each node know to which channel it has to listen at any time. A node u that received a message originated by or designated to one of the nodes in its sub-tree, transmits the message in the next upstream or downstream slot, respectively. In this method the number of required channel is at most R . Note that "channel reuse" techniques can be applied for further reducing the number of required channels. If, for instance, the delivery tree is also an SP tree and non-neighbor nodes do not interfere to each other, it can be shown that only three wireless channels are required for each cluster.

3.2.3 Admission Control

In the proposed system a node is allowed to originate a new message only if it has acquired a reserved slot. Reserved slots are obtained only when a node receives a message from the access point. This raises the problem of initiating new sessions by the cluster nodes. To overcome this problem the access point periodically polls the cluster nodes that are not involved with active sessions. Since, the poll request and replay messages are very short, the access point may poll simultaneously several nodes for minimizing the polling overhead, *i.e.*, a set of nodes with the same parent v in T . The access point sends a single poll message to node v . Upon reception of the poll message, node v polls all its children by transmitting a single poll message. Each child returns a short reply in a corresponding mini-slot. This reply message indicates whether the child wants to initiate a new session and the required bandwidth. Node v collects the replies and originates a single reply message that is sent toward the access point. When the access point receives the reply message, it initiates the requested sessions and allocates the required resources.

3.2.4 Fault Management

In the considered system, each cluster is managed by a single access point. We assume that the access point is backed-up and it is connected to a reliable source of energy, while the other nodes are prone to failures. For failure recovery, the system is equipped with failure detection and failure recovery mechanisms. The failure detection mechanism also uses the polling method for failure detection. If the access point does not receive any reply after sending few poll messages, it assumes that one of the nodes along the message path has failed, and it sends relevant poll messages for identifying the malfunctioning node. Similarly, a node that has not received a poll message during a give time period, assumes that it is no longer connected with the access point and it starts listening to a pre-defined control channel for recovery messages.

Upon a failure, the access point modifies the delivery tree for reconnecting the detached nodes and sends proper recovery messages for reconstructing the delivery tree. If the malfunctioning node is a cut-node of the cluster graph³, the system attempts to attach the disconnected nodes to adjacent clusters.

³A node is termed a cut-node if its removal leaves the graph disconnected.

4. THE SYSTEM DESIGN PROBLEM

We now present the clustering problem that is raised from the design of the multi-hop systems. Consider a graph $G(V, E)$ as describe in Section 2, with bandwidth requirements w_v for every node $v \in V$, capacity W to every wireless channel and a bound D_P on the message propagation delay. The *clustering problem* looks for the minimal number of disjoint delivery trees that cover all the nodes and satisfy three additional design requirements. For presenting these constraints we need the next definition.

DEFINITION 1 (Relay-Load). Consider a delivery tree T and for every non-root node v let $T_v(C', E')$ be the sub-tree of T rooted at node v . The relay-load of node v in T , denoted by $h_v(T)$, is the total weight of all its descendant nodes in the delivery tree T , *i.e.*, $h_v(T) = \sum_{u \in C' - \{v\}} w_u$.

From the description of the delivery mechanism in Section 3.2 results that every delivery tree T must satisfy the following constraints. The aggregated bandwidth requirements of all the tree nodes must not exceed the capacity W of a wireless channel. According to Property 1, the depth of the delivery tree is at most $R = \lfloor \frac{D_P + \Delta}{2 \cdot \Delta} \rfloor$ for satisfying the delay constraint. As, every non-root node v needs to receive and retransmit every message that is originated by or designated to one of its descendant, its relay-load is at most $(W - w_v)/2$.

DEFINITION 2 (The clustering problem). Given a graph $G(V, E)$, a maximal tree depth $R \in \mathcal{Z}^+$ and a maximal weight $W \in \mathcal{R}^+$. Find the smallest collection of sub-graphs (trees) $\mathcal{T} = \{T_1(C_1, E_1), \dots, T_m(C_m, E_m)\}$, $C_i \subseteq V$, $E_i \subseteq E$ that satisfy the following requirements.

1. **Tree Topology** - Every sub-graph $T_i(C_i, E_i)$ has a tree topology and let its root be node $y_i \in C_i$.
2. **Coverage** - The trees contain all the graph nodes, *i.e.*, $\bigcup_{j=1}^m C_j = V$.
3. **Disjoint Trees**- Every node is included in a single tree, *i.e.*, $C_i \cap C_j = \emptyset$, for every $i \neq j$.
4. **Depth** - The depth of every tree $T_i(C_i, E_i) \in \mathcal{T}$ is at most R .
5. **Weight** - For every tree $T_i(C_i, E_i) \in \mathcal{T}$, the total weight of all its nodes is at most W . Thus, $W_{sum}(C_i) = \sum_{v \in C_i} w_v \leq W$.
We assume that for every node $v \in V$, $w_v \leq W/3$.
6. **Relay-Load** - For every tree $T_i(C_i, E_i)$ and for every node $v \in C_i - \{y_i\}$, its relay-load is bounded by $h_v(T_i) \leq (W - w_v)/2$.

THEOREM 1. The clustering problem is NP-hard.

Proof: We reduce any instance of the *dominating set* (DS) problem of unit disk graph to an instance of our clustering problem with $R = 1$ and unbounded W . \square

A graph decomposition \mathcal{T} that satisfies the requirements of Definition 2 is called a *feasible partition* and every tree $T_i \in \mathcal{T}$ is called a *feasible delivery tree*. From the clustering problem formulation it is clear that the root of every feasible delivery tree can serve as an access point. However, the calculated trees are not necessary the ones that minimize the relay-load of the cluster nodes. Minimizing the relay-load of

all the non-root nodes is important for reducing the energy consumption of the nodes (especially in sensor networks) and for failure recovery. Therefore, after calculating the trees $\mathcal{T} = \{T_i(C_i, E_i)\}$ and their corresponding clusters, C_i , we would like to find at each cluster C_i the access point and its corresponding delivery tree that minimize the maximal relay-load of its cluster nodes.

DEFINITION 3 (*The relay-load problem*). Given a cluster C , a corresponding cluster graph $G_C(C, E_C)$ and maximal depth R . Find a node $y \in C$ and a spanning tree T of $G_C(C, E_C)$ rooted at node y with depth at most R that minimizes the function, $\min_{T,y} \{\max_{v \in C_i - \{y\}} h_v(T)\}$.

THEOREM 2. *The relay-load problem is NP-hard.*

Proof: We prove this theorem by mapping any instance of the *partition* problem [20] to a corresponding instance of the relay-load problem. \square

From Theorem 1, we conclude that we cannot find algorithm with approximation ratio better than the lower bound of the dominating set problem. Generally, this lower bound is $\ln(\Lambda)$, where Λ is the maximal degree of the graph nodes. The minimum dominating set problem remains NP-complete also for unit disk graphs [19]. However, in such graphs a solution within a constant factor of the optimum can be found.

5. THE CLUSTERING ALGORITHM

This section describes our clustering algorithm that satisfies all the requirements of Definition 2. The algorithm guarantees a solution within a constant factor of the optimum and it uses the following property,

PROPERTY 3. *Consider a cluster C with cluster-head $y \in C$ and cluster graph $G_C(C, E)$. If for every node $v \in C$ the distance $d_C(y, v) \leq R$, then the depth of any SP tree rooted at node y is at most R , and we say that the cluster C satisfies the depth constraint.*

The algorithm contains four stages. Initially, we select a small set of cluster-heads such that their R -neighborhoods cover all the nodes. From Property 3 follows that these clusters satisfy the depth requirement. In the second stage, each node is assigned to a single cluster without increasing the radius of each cluster graph. Then, at each cluster we select an SP tree rooted at the cluster head. If the selected tree violates the weight or the relay-load requirements, it is further divided into smaller trees (clusters) that satisfy all the requirements of Definition 2. Finally, at each cluster we use a simple heuristic for selecting an access point that reduces the maximal relay-load of the cluster nodes. We use the graph $G(V, E)$ depicted in Figure 1 for demonstrating the different stages of the algorithm, where $R = 5$, and $W = 10$ and the weight of each node $v \in V$ is $w_v = 1$.

5.1 Coverage with Bounded Radius Clusters

Consider a unit disk graph $G(V, E)$ as described in Section 2. The *coverage algorithm* looks for the minimal number of cluster-heads such that their R -neighborhoods cover all the nodes. This is the same as looking for the minimum dominating set of the power graph $G^R(V, E^R)$. In this section we consider three coverage algorithms that guarantee different approximation ratios.

The first approach employs the greedy set cover (SC) algorithm of Chvatal [21] and it is termed a *greedy SC coverage algorithm*. This is an iterative algorithm that selects

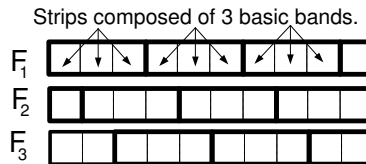

Figure 5: An example of strip sets for $L = 3$ and 10 basic-bands.

at each iteration the node whose R -neighborhood contains the maximal number of uncovered nodes. This algorithm guarantees a solution with in a factor of $\log(\Lambda)$ from the optimum, where Λ is the maximal degree of the nodes in the graph $G^R(V, E^R)$.

In the following we present two additional approximation algorithms that are based on Property 4.

PROPERTY 4. *The R -neighborhood of any node $v \in V$ of the graph $G(V, E)$ [the neighborhood of node v in $G^R(V, E^R)$] is concentrated inside a circle of radius R around node v .*

These algorithms guarantee approximation ratios that do not depend on the number of nodes in the graph or its topology. One algorithm is a polynomial time approximation scheme (PTAS) based on the *shifting strategy* of Hochbaum and Maass [16], which allows us to strike a balance between quality of approximation and its running time. The other algorithm is based on geometric properties of independent sets in unit disk graphs. The latter provides a fast solution with an error bound that linearly grows with R .

5.1.1 The Shifting Strategy Approach

The *shifting strategy* is a useful divide-and-conquer method for bounding the solution error when dealing with geometric problems that consider bounded size objects. In [16], it is used for point-covering problems with bounded size disks. We describe this method for a plane, objects with diameter at most D and a shifting parameter L . Initially, the shifting strategy divides the plane into vertical *basic-bands* of width D . Then it uses the basic-bands to construct L different sets of *strips*, denoted by F_1, F_2, \dots, F_L . Each set contains strips of width $D \cdot L$ (or less) that cover the entire area. The set F_1 is defined by grouping every L consecutive basic-bands to a single strip of width $D \cdot L$ starting from the left most basic-band, as shown in Figure 5. The other sets are defined by shifting each time the $D \cdot L$ strips one basic-band to the right. Note that after L shifts the first set is received. Let A be an algorithm for calculating a solution in any strip of width at most $D \cdot L$. We use algorithm A for calculating a solution for every set $F_l, l \in [1, L]$. Among all the calculated solutions the best one is selected. As proven in [16], the shifting strategy ensures the following upper bound.

THEOREM 3 (THE SHIFTING THEOREM). *Let δ_A be the approximation ratio of algorithm A and let $\delta_{A,L}^{SH}$ be the approximation ratio of the shifting strategy when using algorithm A and shifting parameter L . Then $\delta_{A,L}^{SH} \leq \delta_A \cdot (1 + \frac{1}{L})$.*

Let us now describe our *shifting strategy coverage algorithm*. The latter uses a nested application of the shifting strategy for calculating a small set of cluster-heads of the graph G . Initially, It selects $D = 2 \cdot R$ as the width of a basic-band. From Property 4 results that each cluster is

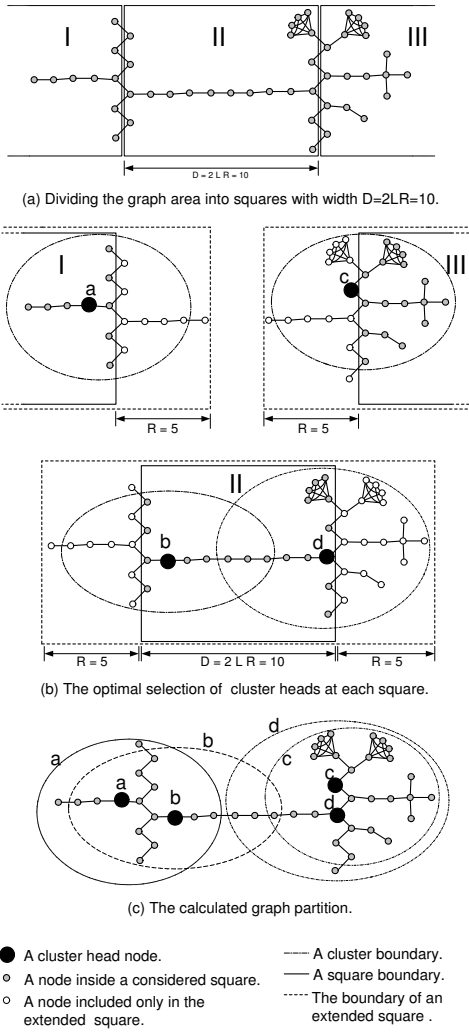

Figure 6: An execution example of the shifting strategy with $R = 5$ and $L = 1$.

covered by at most two basic-bands. The algorithm calculates L sets of vertical strips of width $L \cdot D$, as we describe above. Then, it applies the shifting strategy again on the other dimension, and each strip is further divided into sets of squares each one of size $L \cdot D \times L \cdot D$. At each square, the algorithm finds the optimal set of cluster-heads by performing an exhaustive search, and selects the set of squares (strips) F_l , $l \in [1, L]$ with the minimal number of cluster-heads.

EXAMPLE 4. Consider the graph shown in Figure 1 divided into 3 squares with $D = 2 \cdot L \cdot R = 2 \cdot 1 \cdot 5 = 10$, as depicted in Figure 6-(a). Figure 6-(b) presents the optimal sets of cluster-heads that cover the square nodes. As illustrated by square III, such set may include nodes outside the considered square boundaries (node c in this example). However, the geometric distance of such cluster-heads from the square boundary is at most R . Therefore, each square is surrounded by a ring of width R around it, that defines an *extended square*, and its optimal cluster-head set is selected from this square. Figure 6-(c) depicts the final partition with 4 clusters, which is $1 + \frac{1}{L} = 2$ times the size of optimal partition. \square

We now turn to calculate the running time and the approximation ratio of the proposed algorithm.

LEMMA 1. *The approximation ratio of the coverage algorithm is $(1 + \frac{1}{L})^2$.*

Proof: According to the Shifting Theorem, at each strip a solution within a factor of $(1 + \frac{1}{L})$ is found. As a result, the calculated partition is within a factor of $(1 + \frac{1}{L})^2$ from the optimum solution. \square

LEMMA 2. *The optimal cluster-head set of a square of size $2 \cdot L \cdot R \times 2 \cdot L \cdot R$ contains at most $(2^{\frac{3}{2}} \cdot L \cdot R + 1)^2$ nodes.*

Proof: The proof is based on geometric constraints. We show that this is the maximal number of points that can be arranged inside a square of size $2 \cdot L \cdot R \times 2 \cdot L \cdot R$, such that the geometric distance between every pair of points is at least 1. \square

LEMMA 3. *The complexity of the coverage algorithm is $O\left(L^2 \cdot |V|^{(2^{\frac{3}{2}} \cdot L \cdot R + 1)^2 + 2}\right)$.*

Proof: From Lemma 2, at each square the search routine needs to check only combination of at most $(2^{\frac{3}{2}} \cdot L \cdot R + 1)^2$ nodes for finding the optimal cluster-head set. The square partition algorithm is called at most $|V| \cdot L^2$ times. So, the complexity of the algorithm is $O\left(L^2 \cdot |V|^{(2^{\frac{3}{2}} \cdot L \cdot R + 1)^2 + 2}\right)$. \square

COROLLARY 1. *The shifting strategy coverage algorithm is polynomial time approximation scheme (PTAS).*

Finally, we present an improvement for the shifting strategy, termed the *overlap coverage improvement*. The later does not affect the approximation ratio, but it significantly improves its average performance, as shown in Section 7. Let $F = \{f_1, f_2, \dots, f_k\}$ be a set of disjoint strips (or squares) that covers the considered area and let Y_i be the selected cluster-heads for strip f_i . Recall that for any adjacent pair of strips f_i and f_{i+1} , the clusters defined by Y_i may also cover some nodes of f_{i+1} . Thus, if the sets Y_i and Y_{i+1} are calculated sequentially, the size of Y_{i+1} can be reduced by selecting the minimal set of clusters that covers "uncovered" nodes in f_{i+1} .

5.1.2 The Dominating Independent Set Approach

The shifting strategy enables us to find a near optimal solution with the expense of a high running time. In this section, we present a "fast" greedy algorithm that selects a dominating independent set (DIS) of the power graph $G^R(V, E^R)$ as the set of cluster-heads. The *greedy DIS coverage algorithm* guarantees an approximation factor that is linear with R .

To select a small dominating independent set Y we use a greedy algorithm similar to the one presented in [21]. Let Y be the set of selected cluster-heads, let $\bar{V} \subseteq V$ be the set of uncovered nodes and let $n_v = |N_R(v) \cap \bar{V}|$ be the number of uncovered nodes in the R -neighborhood of v . Initially, $Y \leftarrow \emptyset$, $\bar{V} \leftarrow V$ and for every $v \in \bar{V}$, $n_v \leftarrow |N_R(v)|$. At each iteration, the algorithm selects the node $u \in \bar{V}$ with the maximal n_u value and adds it to Y . Recall that the R -neighborhood of u contains the maximal number of

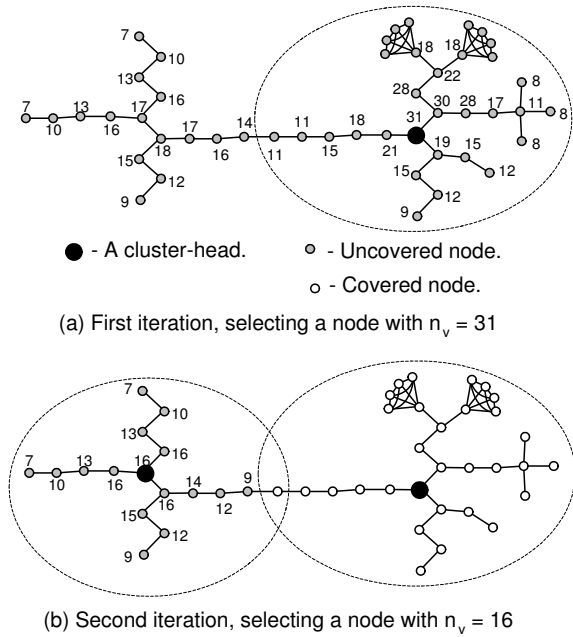

Figure 7: An execution example of the greedy DIS coverage algorithm.

uncovered nodes from all the nodes in \bar{V} . Then, the R -neighborhood of u is removed from the set \bar{V} and for every remaining node $v \in \bar{V}$ its n_v value is recalculated. This step is done until all the nodes are covered, *i.e.*, $\bar{V} = \emptyset$. We now show that the final set Y is a DIS of $G^R(V, E^R)$. Since, the algorithm selects, at each iteration, a node $v \in \bar{V}$ from the set of uncovered nodes, the distance of v from any other node $y \in \bar{V}$ is more than R , *i.e.*, $d((v, y)) > R$. Given that the algorithm ends when $\bar{V} = \emptyset$, every node is included in the R -neighborhood of a node in Y .

EXAMPLE 5. For the graph depicted in Figure 1, the greedy algorithm calculates a set with 2 cluster-heads, as depicted in Figure 7. The number near each node represents its current n_v value. \square

We turn to calculate the approximation ratio of the proposed algorithm. Let H_v be the cluster graph defined by the R -neighborhood of any node $v \in V$ and let H_v^R be the R -th power graph of H_v . We denote by $M(R)$ the upper bound on the size of any independent set of H_v^R . The proof of Lemma 4 is given in Appendix A.

LEMMA 4. *The size of any independent set of the graph H_v^R is at most $M(R) \leq 8 \cdot R + 10$.*

LEMMA 5. *Let IS be any independent set of the graph $G^R(V, E^R)$ and let DS^* be its minimum dominating set. Then, $|IS| \leq M(R) \cdot |DS^*|$.*

Proof: Since DS^* is a dominating set of G^R , each node $v \in V$ is included in the R -neighborhood of at least one node in DS^* . From Lemma 4, the set IS contains at most $M(R)$ nodes from the R -neighborhood of any node in DS^* . As a result, $|IS| \leq M(R) \cdot |DS^*|$. \square

COROLLARY 2. *The approximation ratio of the greedy DIS coverage algorithm is $M(R)$.*

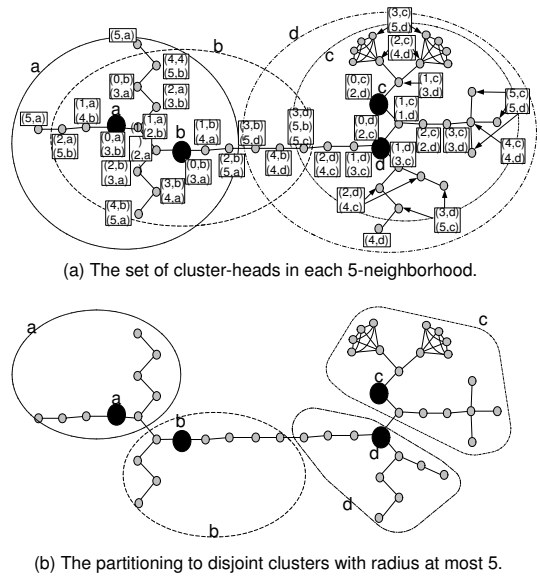

Figure 8: An execution example of the partition refinement algorithm.

5.2 Creating Disjoint Clusters

The coverage algorithms in the first stage find small number of clusters that contain all the graph nodes, however these clusters may overlap. In the second stage, the *cluster refinement algorithm* separates these clusters to disjoint connected clusters. Let Y be the set of cluster-heads and assume that every cluster is represented by its cluster-head $y_i \in Y$. The algorithm associates each node with its closest cluster-head $y_i \in Y$, and breaks ties by selecting the cluster-head with the lowest ID. Since, all the nodes are covered by the clusters defined by Y , the selected cluster-head of each node is included in its R -neighborhood and their distance is at most R .

EXAMPLE 6. In Figure 8 we demonstrate an execution of the cluster refinement algorithm when the input is the four cluster-heads described in Figure 6-(c). Figure 8-(a) presents, for each node v , the list of cluster-heads in its R -neighborhood sorted according to their distance from v . The partition to disjoint clusters is presented in Figure 8-(b). \square

LEMMA 6. *The cluster refinement algorithm defines $|Y|$ disjoint connected clusters that contain all the graph nodes and satisfy the depth requirement.*

Proof: It is clear that the cluster refinement algorithm creates $|Y|$ disjoint clusters. We only have to show that these clusters are connected and their radius is at most R . The latter results from the next observation. Suppose that node $v \in V$ is associated with a cluster-head $y_i \in Y$, then every node w along any shortest path from v to y_i is also associated with y_i . Thus, the cluster of y_i must be connected and its radius is at most R . \square

5.3 Satisfying the Weight and the Relay-load Requirements

In the third stage, the *weight partition algorithm* selects an SP tree for each cluster rooted at the cluster-head. If

the SP tree violates either the weight or the relay-load constraints it is divided into smaller sub-trees that meet all the requirements. Our algorithm extends the clustering scheme of Banerjee and Khuller [15] and uses the next property of unit disk graphs, proven in [15].

PROPERTY 5. *The maximum independent set of the graph defined by the neighborhood, $N(u)$, of any node u has at most 5 nodes, i.e., $M(1) = 5$.*

Consider a cluster C with cluster head $y \in C$. Initially, the algorithm calculates an SP tree, T , of the cluster graph rooted at node y . Recall that the depth of T is at most R and let us denote by T_u the sub-tree of T rooted at node u . Then, the algorithm performs a post-order tour of the tree, in which it calculates the total weight, $W_{tree}(u)$, of every sub-tree T_u , $u \in C$. Each time, a sub-tree T_u that violates the relay-load requirement is found, i.e., $W_{tree}(u) > (W + w_u)/2$, it is removed from T and becomes a separate delivery tree rooted at node u . Since, the relay-load constraint is specified only for non-cluster-head nodes, the new tree satisfies the relay-load requirement. If, in addition, the total weight of T_u exceeds the weight constraint, we use a *local pruning routine* for dividing T_u into minimal number of trees that satisfies also the weight requirement.

Consider a sub-tree T_u with weight more than W and let K_u be the children of u . We denote by $W_{tree}(v) = \sum_{x \in T_v} w_x$ the total weight of the nodes in the sub-tree T_v . For every set of nodes, S let $W_{tree}(S) = \sum_{v \in S} W_{tree}(v)$. The local pruning routine minimizes the number of newly generated trees in the following way. It divides K_u into a small number of sets, such that each set S and its related sub-trees T_v , $v \in S$ induce a tree that meets the depth, weight and relay-load requirements. While the weight of the tree T_u is more than W , $W_{tree}(u) > W$, the routine selects the set S with the maximal $W_{tree}(S)$ weight, removes S and its associated sub-trees from T_u and updates the tree weight, i.e., $W_{tree}(u) \leftarrow W_{tree}(u) - W_{tree}(S)$. The set S and its attached sub-trees become a new tree (cluster).

It is clear, that an efficient partition of K_u into a small number of sets is essential for achieving low approximation ratio. The local pruning routine minimizes the numbers of sets by using an iterative method that creates a single set at each iteration. Let $Q \subseteq K_u$ be the set of nodes that are not assigned to any set S . At the beginning $Q \leftarrow K_u$. While Q is not empty the routine performs the following loop. It selects a *seed node*, $v \in Q$, removes it from Q and creates a new set $S = \{v\}$ with $W_{tree}(S) \leftarrow W_{tree}(v)$. While there is any node $x \in N(v) \cap Q$ such that $W_{tree}(x) + W_{tree}(S) \leq W$, the routine adds x to the set S , removes x from Q and updates $W_{tree}(S) \leftarrow W_{tree}(S) + W_{tree}(x)$. At the end, by connecting node v with the other nodes in S , a new tree, T' , is defined. Thus, the trees calculated by the weight partition algorithm satisfy all the requirements of Definition 2.

EXAMPLE 7. Consider the 4 clusters calculated in Example 6 and let $W = 10$. In this example, cluster c violates the weight requirement and the SP tree of cluster d violates the relay-load constraint. We illustrate the weight partition of cluster c in Figure 9. The solid lines represent the SP-tree T and the nodes are enumerated according to the post-order-tour starting from node c . The sub-tree, T_u , routed at node u (number 11) has a weight $W_{tree}(u) = 11 > W$. Therefore, it violates both the relay-load and the weight requirements. The local pruning routine overcomes this weight violation by removing T_u from T and dividing it into two smaller

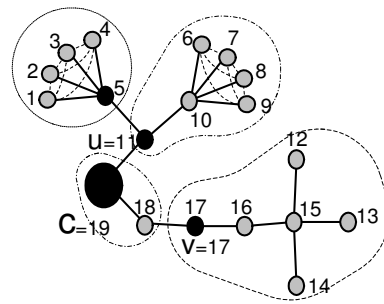

Figure 9: An execution example of the weight partition algorithm.

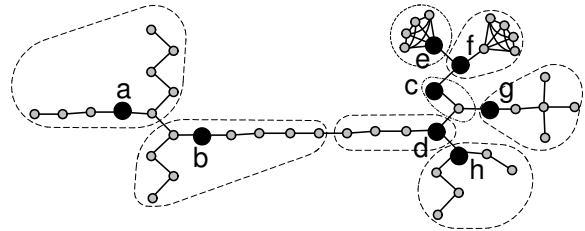

Figure 10: The final partition of the graph.

clusters. Similarly, the tree T_v (node $v = 17$) violates the relay-load requirement, as $W_{tree}(T_v) = 6 > (10+1)/2 = 5.5$, and it is removed from T . Consequently, the entire graph is divided into eight clusters that meet all the requirements, as depicted in Figure 10. \square

We now present the approximation ratio of the weight partition algorithm. This ratio is independent of the used heuristics for selecting the SP tree or the seed nodes and the proofs of Lemmas 7 and 8 are given in Appendix B.

LEMMA 7. *The weight partition algorithm divides the cluster graph into disjoint trees that contain all the cluster nodes and satisfy the depth, relay-load and the weight constraints.*

LEMMA 8. *Let \overline{W}_{sum} be the average weight of a cluster defined by the weight partition algorithm. Then $\overline{W}_{sum} \geq W/3$ and the approximation ratio of the weight partition algorithm is 3.*

5.4 Reducing the Maximal Relay Load

So far, we described the algorithms for partitioning the graph into small number of trees that satisfy the clustering requirements of Definition 2. Each tree $T_i(C_i, E_i)$ represents a cluster of nodes C_i served by an access point that is located at the tree root, $y_i \in C_i$. However, a calculated tree T_i is not necessary the optimal tree for minimizing the maximal relay-load of the cluster nodes. For instance, in Figure 10, each one of the tree roots of the clusters d, f and g has a single child. Thus, we can reduce the maximal relay-load at each one of these clusters by selecting as an access point a node that is closer to the tree center. According to Theorem 2, finding the optimal delivery tree of a cluster is NP-hard. Here, we propose a simple heuristic for reducing the maximal relay load. The heuristic considers all the nodes $v \in C_i$ that can serve as root of the tree T_i without violating the depth requirement, and selects as the access point the one that minimizes the maximal relay-load.

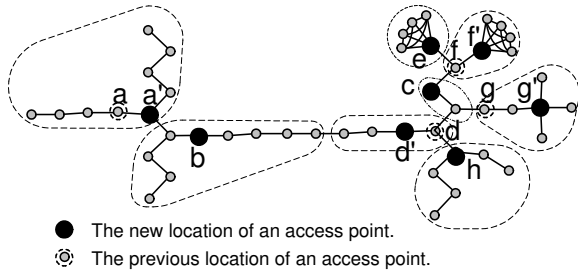

Figure 11: The final partition of the graph.

Evaluated alg. ($R = 1$)	$L = 1$	$L = 2$	$L = 3$
Shift alg.	277	252	231
Improved Shift alg.	243	229	220

Table 1: The number of calculated clusters by the shifting algorithm for $R = 1$ and $L \in [1, 3]$ without weight constraint.

EXAMPLE 8. Figure 11 presents the new locations of the access points. The current maximal relay-loads of clusters e and g are 0 and 2, respectively (instead of 4 before). \square

6. THE APPROXIMATION RATIO OF THE CLUSTERING ALGORITHMS

This section presents the approximation ratios of the proposed clustering algorithms. The algorithms are termed according to the coverage scheme that they apply; the *shifting clustering algorithm*, the *greedy DIS clustering algorithm* and the *greedy SC clustering algorithm*.

THEOREM 4. *The approximation ratio of the shifting clustering algorithm is $(1 + \frac{1}{L})^2 + 3$, where L is the shifting parameter.*

Proof: Let OPT be the size of the optimal partition. According to Lemma 1, the number of clusters produced by coverage algorithm is at most $(1 + \frac{1}{L})^2 \cdot OPT$. From Lemma 6, the cluster refinement algorithm does not increase the number of clusters. From Lemma 8 follows that the number of clusters added by the weight partition algorithm is at most $3 \cdot OPT$. Thus, the total number of clusters is at most $[(1 + \frac{1}{L})^2 + 3] \cdot OPT$. \square

Moreover, the time complexity of shifting clustering algorithm is $O\left(L^2 \cdot |V|^{(2^{\frac{3}{2}} \cdot L \cdot R + 1)^2 + 2}\right)$.

THEOREM 5. *The approximation ratio of greedy DIS clustering algorithm is $M(R) + 3 = 8 \cdot R + 13$, where R is the maximal depth.*

THEOREM 6. *The approximation ratio of greedy SC clustering algorithm is $\log(\Lambda) + 3$, where Λ is the size of the maximal R -neighborhood.*

The proofs of Theorems 5 and 6 are similar to the proof of Theorem 4 and the running time of the greedy algorithms is $O(|V|^3)$. Although, these algorithms have different approximation ratios, on average they yield similar results, as we show in Section 7.

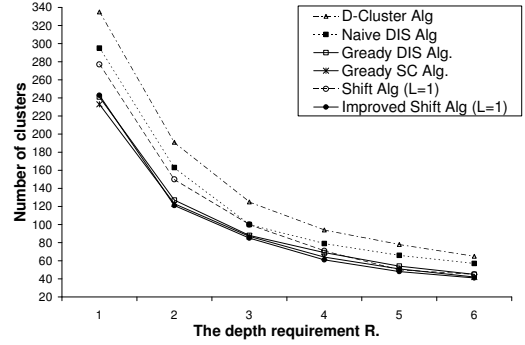

Figure 12: A comparison between the different coverage algorithms (without weight constraint).

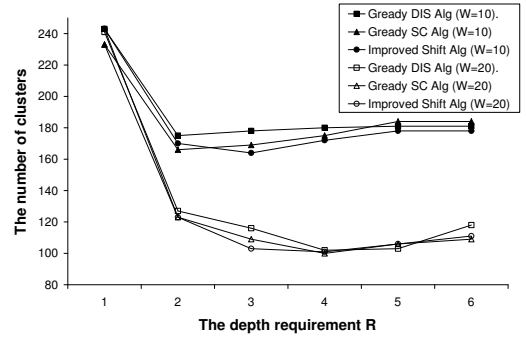

Figure 13: A comparison between the different algorithms with weight constraint $W = 10$ and 30 .

7. SIMULATION RESULTS

We compared by simulations the performance of the three algorithms proposed in this work and other algorithms described in the literature. The algorithms are evaluated by the number of clusters that they produce. In our simulation we evaluated separately the following coverage algorithms; of R and L and the considered algorithms are; the *greedy SC algorithm* presented in Section 5.1, the *shifting algorithm* described in Section 5.1.1 with and without the *overlap coverage improvement*⁴, the *greedy DIS algorithm* described in Section 5.1.2, the *D-cluster algorithm* presented in [12] and a *naive DIS algorithm* that finds arbitrary DIS sets. Then, we also compared the sizes of the final solutions that satisfy also the weight and the relay-load constraints. Selected typical results of our simulations are given in Figures 12–14 and Table 1 for different values of L , R and W . Due to space limitation, we present the number of clusters produced by the different algorithms for a single network with 1000 nodes, that are uniformly distributed over a square area of size 30×30 (The transmission range of very node is a circle with radius 1). Additional simulations of other networks with various sizes yield very similar results.

Initially, we evaluated the effect of the shifting parameter on the performance of the two variants of the shifting algorithm with $R = 1$ and unbounded cluster weight. Table 1

⁴The "improved shift alg" denotes the shifting algorithm with the overlap coverage improvement.

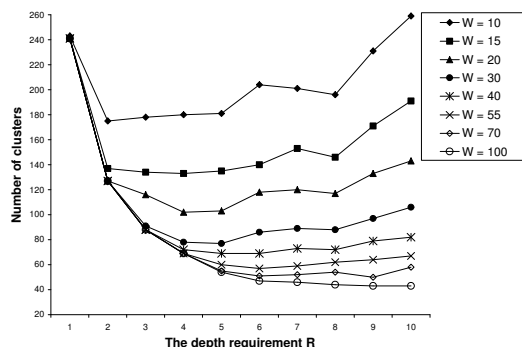

Figure 14: Performance evaluation of the greedy DIS algorithm for different values of R and W .

summarizes our results and shows that indeed better results are obtained by increasing the shifting parameter L . However, this improvement is minor relative to the significantly expansion of the simulation running time. From Table 1, we conclude that the improved shifting algorithm obtains near optimal results also for $L = 1$ and we use this value in the rest of our discussion.

Figure 12 presents the number of clusters calculated by the different coverage algorithms without the weight constraint. It shows that the greedy SC, greedy DIS and the improved shifting algorithms yield very similar results close to the optimal one and outperform the D-cluster and the naive DIS algorithms (therefore, we omit the latter two from the following charts). Moreover, the improved shifting algorithm finds slightly better solution than the two greedy algorithms. Figure 13 confirms this observation also when $W = 10$ and 20. Figure 13 also shows that the number of required access points is significantly smaller in multi-hop systems than in single-hop systems, even if W is small. Finally, Figure 14 presents the number of clusters calculated by the "greedy DIS alg." for different values of W and R .

Moreover, Figures 13 and 14 present an unexpected result. Intuitively, for a given weight W , we expect the number of clusters to decrease by increasing the value of R until it converges to some value. In practice, our simulations show that for every W there is an optimal depth, R^* , that minimizes the number of clusters and after this point more clusters are created. As an example, for $W = 10$ the optimal depth is $R^* = 2$ or 3 (depend on the applied algorithm), while for $W = 20$ the optimal depth is $R^* = 4$ or 5. This phenomenon results from the efficiency of the weight partition algorithm. Since, the weight partition algorithm allows the average cluster size to be as small as $W/3$, it produces clusters that are small in comparison to those of the optimal partition. As a result, a large value of R yields smaller number of clusters with radius R (calculated by a coverage algorithm), but these clusters exceed the weight constraint and are further divided into many small clusters. Consequently, we conclude that efficient solution requires a balance between the weight and the depth parameters.

8. CONCLUSIONS AND FUTURE WORK

This work presents an efficient and low-cost infrastructure for connecting static multi-hop wireless networks with fixed backbone network. This infrastructure can be used for re-

ducing the cost of BWA systems and for accessing sensor networks. It presents clustering algorithms that partition a given wireless network into a forest with small number of trees, when each tree serves as delivery tree of a single access point. For QoS assurance, these trees also satisfy depth, weight and relay-load constraints. The work also describes an efficient delivery mechanism that maximizes the cluster throughput without violating the given QoS constraints. Although, the paper consider most of the design aspects of the proposed infrastructure, it leaves some open questions. For instance, the design of a recovery mechanism and finding an efficient algorithm for the relay-load problem.

9. ACKNOWLEDGEMENT

I would like to thank Bulent Yener for useful discussions and to Eran Gabber, Rajeev Rastogi and Mark Smith for their helpful comments.

10. REFERENCES

- [1] H. Bolcskei, A. J. Paulraj, K. V. S. Hari, R. Nabar and W. W. Lu. "Fixed Broadband Wireless Access: State of the Art, Challenges and future Directions". *Proc. IEEE Comm. Magazine*, Vol. 39, No. 1, January 2001.
- [2] G. Asada, M. Dong, T. S. Lin, F. Newberg, G. Pottie, W. J. Kaiser, and H. O. Marcu. "Wireless Integrated Network Sensors: Low Power Systems on a Chip", *Proc. of European Solid State Circuits Conference*, 1998.
- [3] W. R. Heinzelman, J. Kulik and H. Balakrishnan. "Adaptive Protocol for Information Dissemination in Wireless Sensor Networks", *Proc. of ACM MOBICOM'99*, 1999.
- [4] D. A. Beyer, M. D. Vestrich and J. J. Garcia-Luna-Aceves, "The Rooftop Community Network: Free, High-Speed Network Access for Communities", a chapter in "The First 100 Feet: Options for Internet and Broadband Access" Ed. D. Hurlley and J. H. Keller. *MIT Press: Cambridge* 1999.
- [5] "Wireless Networking Reference - Community Wireless/Rooftop Systems", http://www.practicallynetworked.com/tools/wireless_articles_community.htm.
- [6] P.-H. Hsiao, A. Hwang, H. T. Kung and Dario Vlah. "Load Balancing Routing for Wireless Access Networks". *Proc. of IEEE INFOCOM '01*, 2001.
- [7] R. Krishnan, R. Ramanathan, and M. Steenstrup, "Optimization Algorithms for Large Self-Structuring Networks", *Proc. of IEEE INFOCOM '99*, 1999.
- [8] N. Linial and M. Saks, "Low Diameter Graph Decompositions", *Combinatorica*, Vol. 13, No. 4, 1993.
- [9] B. Awerbuch, B. Berger, L. Cowen, and D. Peleg, "Fast distributed network decomposition and covers", *Journal of Parallel and Distributed Computing*, Vol. 39, No. 2, 1996.
- [10] C. R. Lin and M. Gerla, "Adaptive Clustering for Mobile Wireless Networks", *IEEE Journal of Selected Areas in Communications*, Vol. 15, No. 7, 1997.
- [11] R. Ramanathan and M. Steenstrup, "Hierarchically-Organized, Multihop Mobile Wireless Networks for Quality-of-Service Support", *Mobile Networks and Applications*, Vol. 3, No. 1, 1998.
- [12] A. D. Amis and R. Prakash and T. H. V. Vuong and D. T. Huynh. "Max-Min D-Cluster Formation in Wireless Ad Hoc Networks", *Proc. of IEEE INFOCOM 2000*, 2000.
- [13] B. Liang and Z. J. Haas, "Virtual Backbone Generation and Maintenance in Ad Hoc Network Mobility Management", *Proc. of IEEE INFOCOM*, 2000.
- [14] *IEEE Journal of Selected Areas in Communications*, Vol. 17, No. 8, Aug. 1999.
- [15] S. Banerjee and S. Khuller. "A Clustering Scheme for Hierarchical Control in Wireless Networks". *Proc. IEEE INFOCOM 2001*.

- [16] D. S. Hochbaum and W. Maass, "Approximation Schemes for Covering and Packing Problems in Image Processing and VLSI", *Journal of the ACM*, 32-1, 1985.
- [17] Y. Bejerano, "Efficient Integration of Multi-hop Wireless and Wired Networks with QoS Constraints", Technical Memorandum, Bell-Labs, Lucent Technologies, 2002.
- [18] D. B. Shmoys, E. Tardos and K. Aardal. "Approximation Algorithms for Facility Location Problems", *Proc. of ACM Symposium on Theory of Computing*, 1997.
- [19] B. N. Clark, C. J. Colbourn, and D. S. Johnson. Unit Disk Graphs. *Discrete Mathematics*, 86:165-177, 1990.
- [20] M. R. Garey and D. S. Johnson. Computers and Intractability: A Guide to the Theory of NP-completeness. *Freeman Publication*, New York, 1979.
- [21] V. Chvatal, "A Greedy Heuristic for the Set-Covering Problem", *Math. of Operation Research*, Vol. 4, No. 3, 1979.

APPENDIX

A. THE PROOF OF LEMMA 4

This proof is based on geometric considerations and we consider $R \geq 3$. Assume a cluster graph, H_v , defined by the R -neighborhood of any node $v \in V$ and let H_v^R be the R -th power graph of H_v . Let IS be the maximum independent set of H_v^R . We divide the set IS into two subsets $IS_{far}, IS_{near} \subseteq IS$. The sets IS_{far} and IS_{near} contains all the nodes of IS that their geometric distance from node v is at least or at most $\lfloor \frac{R}{2} \rfloor + 1$, respectively. Let $M_{far}(R)$ and $M_{near}(R)$ be the upper bounds of IS_{far} and IS_{near} , correspondingly. For every node $u \in IS$ let $P(u) = \{u = x_0, x_1, \dots, x_k = v\}$, $k \leq R$, be its shortest path to node v and let $p(u) = \{u = x_0, x_1, \dots, x_J\}$ be the prefix of size $J = \lfloor \frac{R-1}{2} \rfloor$ of $P(u)$. Recall that every node $u \in IS$, except at the most one, has $|P(u)| > R/2$. Thus, it has a prefix of size J . We say that two prefixes $p(u_1)$ and $p(u_2)$ are *remote* if the distance of every pair of nodes $x_1 \in p(u_1)$ and $x_2 \in p(u_2)$ is at least 1. Since the hop count distance of every pair $u_1, u_2 \in IS$ is $d(u_1, u_2) > R$, their prefixes must be remote. Thus, the maximum possible independent set is obtained by maximizing the number of remote prefixes. Now we turn to calculate the maximal number of remote prefixes in IS_{far} and IS_{near} .

Claim 1: For $R \geq 3$, $M_{far}(R) \leq 4 \cdot R$.

proof: The distance of v from the J -th node, $x_J \in p(u)$, of every $u \in IS_{far}$ is at most $R - \lfloor \frac{R-1}{2} \rfloor = \lfloor \frac{R}{2} \rfloor + 1$. Thus, the size of IS_{far} is bounded by the number of suffixes that their last nodes are included inside the circle of radius $\lfloor \frac{R}{2} \rfloor + 1$ around node v . From geometric constraints, this number upper bound by $4 \cdot R$. \square

Claim 2: For $R \geq 3$, $M_{near}(R) \leq 4 \cdot R + 10$.

proof: This proof is based on associating a maximal area $A(u)$ to the suffix of each node $u \in IS_{near}$, such that for any pair $u_1, u_2 \in IS_{near}$ the areas $A(u_1)$ and $A(u_2)$ do not intersect. From geometric constraints, the size of such area $A(u)$ is at least $\pi \cdot R/16$. Thus, the number of nodes in IS_{near} is bounded by $M_{near}(R) \leq \frac{4}{R} \cdot (R^2 + 2 \cdot R + 1)$. \square Thus, from claims 1 and 2, we get that $M(R) \leq 8 \cdot R + 10$.

B. THE APPROXIMATION RATIO OF THE WEIGHT PARTITION ALGORITHM

We now prove the correctness and the approximation ratio of the *weight partition algorithm* (see Section 5.3). Initially, we show that the algorithm meets all the requirements.

Proof of Lemma 7: The algorithm defines an SP-tree T and divides it into smaller sub-trees. Thus, every node is included in exactly one tree. Every sub-tree of T that violates the weight and the relay-load constraints is removed from T and divided into smaller sub-trees. Thus, the calculated trees meet also these two requirements. Every new tree rooted at any node u is created by merging several sub-trees $T_v, v \in N(u)$. The depth of every sub-tree $T_v, v \in C - \{y\}$ is at most $R - 1$. Therefore, the depth of the resulting tree is at most R and the calculated trees satisfy also the depth requirement. \square

Moreover, it can be shown that the algorithm running time is $O(|V|^3)$. Let us now turn to calculate the algorithm approximation ratio. Consider a connected cluster graph $G_C(V_C, E_C)$ that satisfy the depth requirement and let y be its cluster-head. We denote by T the SP-tree calculated by the algorithm. Lemma 9 results directly from Property 5.

LEMMA 9. *The maximum independent set of the graph induced by the set of children $K_u, u \in V_C - \{y\}$, has at most 4 nodes.*

LEMMA 10. *Let \mathcal{S} be a collection of sets calculated by the local pruning routine. Then \mathcal{S} contains at most 4 sets $S \in \mathcal{S}$ with $W_{tree}(S) \leq W/2$.*

Proof: Consider a set K_u and its partition into sets, \mathcal{S} . Let $\mathcal{S}' \subseteq \mathcal{S}$ be the collection of sets $S \in \mathcal{S}$ with $W_{tree}(S) \leq W/2$ and suppose, in contrast, that $|\mathcal{S}'| > 4$. From, the algorithm results that the seed nodes of the sets $S \in \mathcal{S}'$ define an independent set of the graph induced by K_u . But, this contradicts Lemma 9. \square

LEMMA 11. *Consider a partition of a given sub-tree $T_u, u \neq y$, to k clusters by the local pruning routine. Then $k < \frac{3 \cdot W_{tree}(u)}{W}$.*

Proof: Let C_1, \dots, C_k be the clustered created by the local pruning algorithm labeled according to their creation order. Each cluster $C_j, 1 \leq j < k$, is associated with a single set $S_i \subseteq K_u$. Hence, $W_{sum}(C_j) = W_{tree}(S_j)$. From Lemma 10, the routine may define at most 4 sets S such that $W_{tree}(S) \leq W/3$. In such case at least the two smallest sets remain connected to node u , (assuming $w_u \leq W/3$). From this we conclude that for every $1 \leq j \leq k - 3$, $W_{sum}(C_j) > W/3$ and $W_{sum}(C_{k-2}) + W_{sum}(C_{k-1}) + W_{sum}(C_k) > W$. \square

COROLLARY 3. *Let y be the root of the tree T and consider and assume a partition of the tree T_y to k clusters by the local pruning routine. Then $k \leq \frac{3 \cdot W_{tree}(y)}{W}$.*

LEMMA 12. *The approximation ratio of the weight partition algorithm is 3.*

Proof: Let OPT_W be the number of clusters in the optimal partition of $G_C(V_C, E_C)$ to connected clusters that satisfy all the requirements, and let RES_W be the number of clusters created by the weight partition algorithm. Recall that $RES_W - 1$ clusters are created by the local pruning routine and an additional cluster contains the cluster-head y . According to Lemma 11 and Corollary 3, $RES_W < \frac{3 \cdot W_{sum}(T)}{W} + 1$. Moreover, $OPT_W \geq \lceil W_{sum}(T)/W \rceil$. Since, RES_W and OPT_W are integers follows that $RES_W \leq 3 \cdot OPT_W$. \square